

GRReddy TURBO KIT

Scion FR-S ZN6
Subaru BRZ ZC6
GTX2867R Gen2 (Internal Wastegate)

Installation

GPP P/N # 11518000

!

Vehicle Type	Chassis Code	Engine Code	Transmission	Model Year
Scion FR-S	DBA-ZN6	FA20	6MT/AT	2013 ~
Subaru BRZ	DBA-ZC6	FA20	6MT/AT	2013 ~

- Note : ○ For installation this kit requires replacing the factory radiator fans with low profile radiator fans. [like 2x SPAL Low Profile 9" fans SPAL Part# 30100381]
- Fuel management upgrades and tuning are also required to complete the installation. {Contact your favorite Authorized GReddy Dealer for options.}

The manufacturer state that the exhaust manifold nuts should not be reused.

Please purchase new parts from the dealer prior to installation of this turbo kit.

Scion Part # SU003-02873

Subaru Part # 902370010

IMPORTANT!

In many states, it is unlawful to tamper with your vehicle's emissions equipment. GReddy / GPP (GReddy Performance Products, Inc.) products are designed and sold for sanctioned off-road/competition, non-emissions controlled vehicles only and may never be used on a public road or highway. Using GReddy/GPP products for street/road use on public roads or highways is prohibited by law unless a specific regulatory exemption exists (more information can be found on the SEMA Action Network website: www.semasan.com/emissions for state by state details in the USA.) It is the responsibility of the installer and/or user of this product to ensure compliance with all applicable local and federal laws and regulations. Please check with your local vehicle authority before purchasing, using or installing any GReddy/GPP product.

1. Parts List

1. Turbo Charger	Garrett GTX2867R Gen II actuator turbo		1
2. Exhaust Manifold	(SUS 42.7φ-50.8φ)		1
3. Down Pipe	(50φ-60φ)		1
4. Test Pipe			1
5. Compression Tube	C-1	(Aluminum 2.0"φ)	1
6. Compression Tube	C-2	(Aluminum 3.0"φ)	1
7. Compression Tube	C-3	(Aluminum 3.0"φ)	1
8. GPP	Open Air Filter Element		1
9. Intake Tube	(Aluminum 3.0"φ)		1
10. Intercooler Type 24			1
11. Oil Pressure Hose	SUS 600mm		1
12. Oil Pressure Hose	Banjo Bolt Male Female (small)		1 set
13. Oil Pressure Hose	Copper Crush Washer 10φ (t=1.0)		3
14. Oil Pressure Hose	Fitting 3 Way 1/8PT×3		1
15. Oil Pressure Hose	Fitting Straight - Turbo Feed		1
16. Oil Pressure Hose	Fitting 1/8PT-1/8PF		1
17. Oil Return Tube with Flange	16φ		1
18. Oil Return Tube (Weld onto Oil Pan)	16φ		1
19. Straight Union Nipple	1/8PT-5φ		1
20. Hose Union	12φ		1
21. Silicone Cap	15.5φ		1
22. Vacuum	5φ×150mm		1
23. Blow By Hose	12φ×150mm		1
24. Oil Return Hose	15φ×290mm		1
25. Turbo Water Lines	3/8"φ		2
26. Silicone Hose	50φ×70mm		1
27. Silicone Hose	70φ×70mm		2
28. Reducer Hose	50φ×70φ		1
29. Reducer Hose	70φ-80φ		2
30. Hose Clamp	12φ	Tridon #6	4
31. Hose Clamp	16φ	Tridon #8	2
32. Hose Clamp	50φ	Tridon #32	3

34.	Hose Clamp	70φ	Tridon #44						9
35.	Gasket	Turbine IN							1
36.	Gasket	Turbine OUT							1
37.	Turbo Water line Banjo Fittings								2
38.	Gasket	Small Oil Return							1
39.	Gasket	Cylinder Head to Turbo Manifold (Exhaust Manifold)							2
40.	Gasket	Test Pipe							2
41.	Heat Shield	Turbine							1
42.	Heat Shield	Turbo Manifold							1
43.	Heat Wrap	100mm × 1000mm							2
44.	Zip Tie	150mm							10
45.	Turbo Mounting Bracket	A							1
46.	Turbo Mounting Bracket	B							1
47.	Steel Spacer	A Turbo Bracket to Pulley							1
48.	Steel Spacer	B Turbo Bracket to Pulley							1
49.	Oil Return Hose Bracket								1
50.	Test Pipe Bracket								1
51.	Intercooler Bracket								1
52.									
53.	Bracket – Radiator Reservoir Tank relocation								1
54.	N/A								0
55.	M4 × 10mm	P0. 7		Cap Bolt				(Airflow Sensor)	2
56.	M5 × 10mm	P0. 8	Stainless	Cap Bolt				(Exhaust Manifold Heat Shield)	4
57.	M6 × 8mm	P1. 0	Steel	Bolt Set				(Turbine Heat Shield)	3
58.	M6 × 15mm	P1. 25	Stainless	B S/W	—	—		(Oil Return)	2
59.	M6 × 15mm	P1. 0	Stainless	B S/W	F/W	—		(Intercooler Upper Bracket)	1
60.	M6 × 30mm	P1. 0	Stainless	B	—	—	—	(Intercooler Lower Bracket)	2
61.	M6	P1. 0	Steel	Flange Nut				(Intercooler Lower Bracket)	2
62.	M8 × 15mm	P1. 25	Stainless	B S/W	F/W	—		(Intercooler)	1
63.	M8 × 20mm	P1. 25	Stainless	B S/W	F/W	—		(Turbine Bracket)	4
64.	M8 × 35mm	P1. 25	Stainless	B S/W	F/W	N		(Turbine In)	1
65.	M8 × 30mm	P1. 25	Stainless Stud	B S/W	—	N		(Turbine In)	3
66.	M8 × 33mm	P1. 25	Stainless Stud	B S/W	—	N		(Turbine Out)	5
67.	M10 × 35mm	P1. 25	Steel	B S/W	—	N		(Down Pipe & Test Pipe)	4
68.	M10 × 50mm	P1. 25	Steel	Flange Nut				(Turbine Bracket)	2

Parts List Diagram



1



2



3



4



5



6



7



8



9

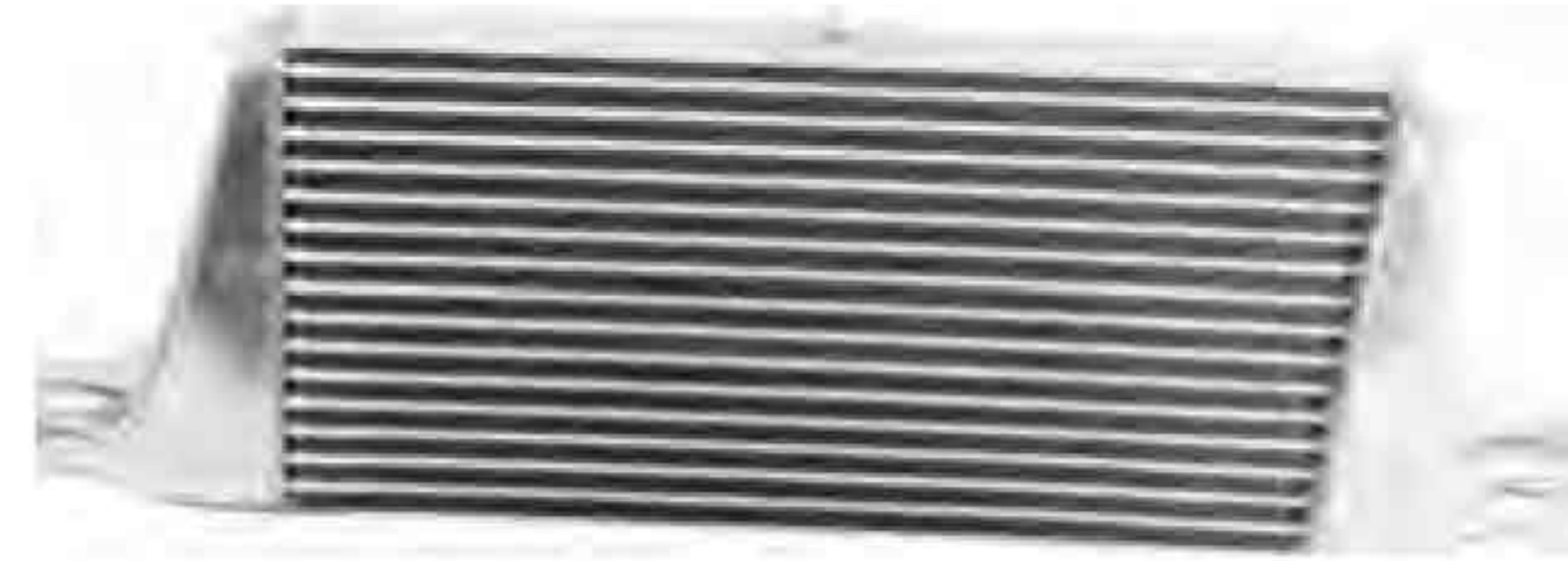

10



11

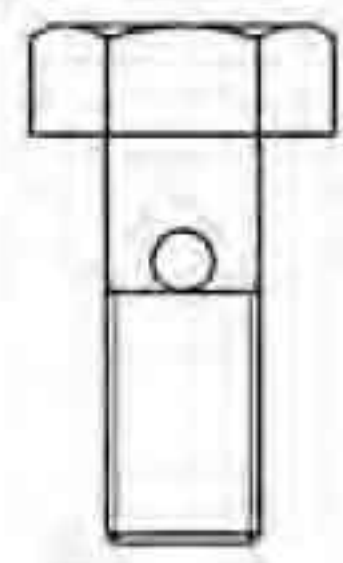

12

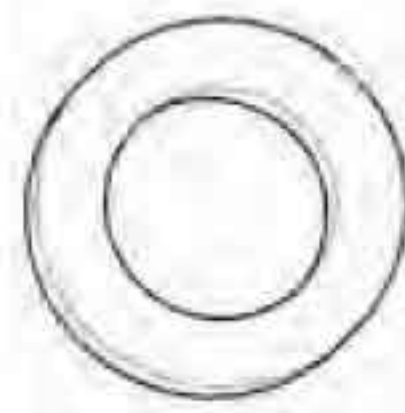

13



14



15

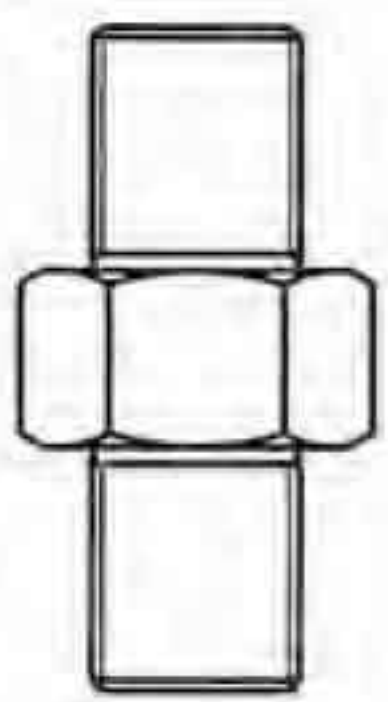

16



17



18

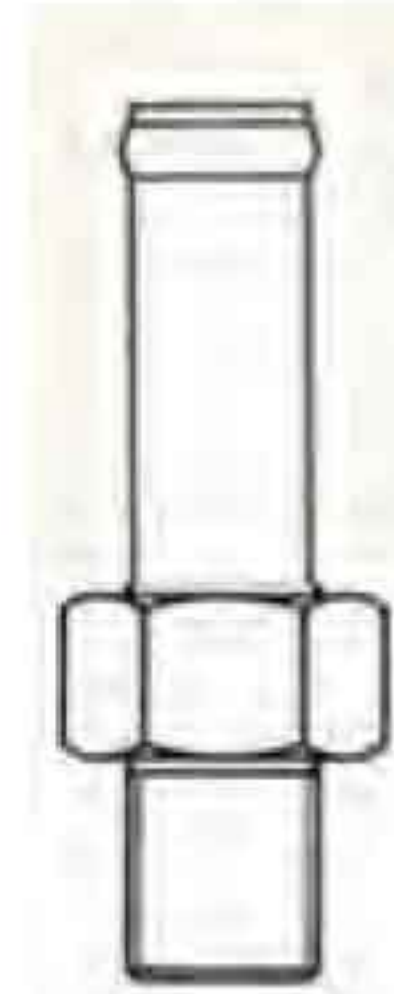

19

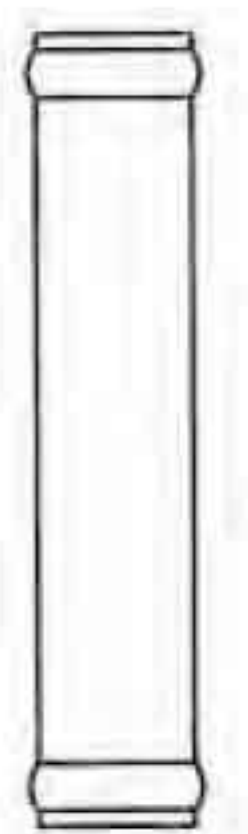

20

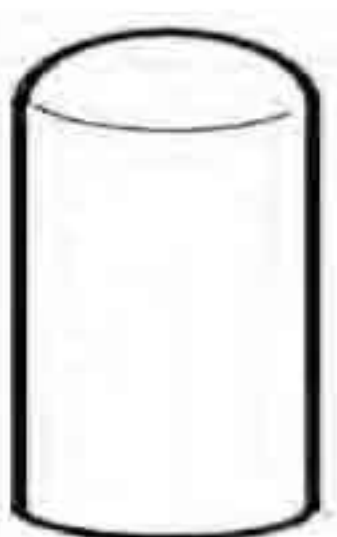

21



22~25

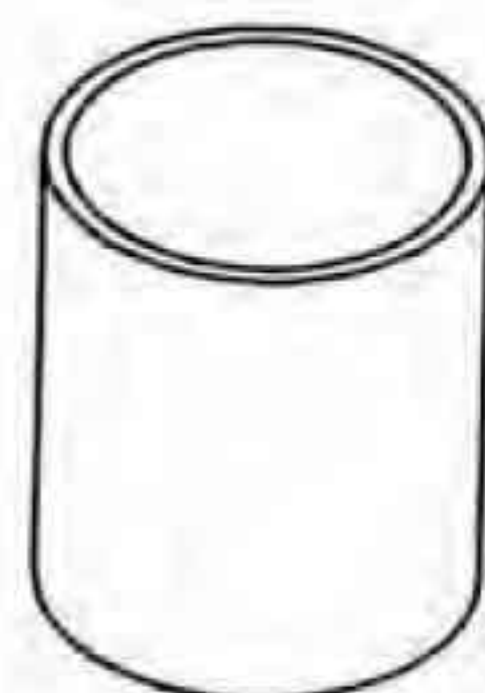

26~27

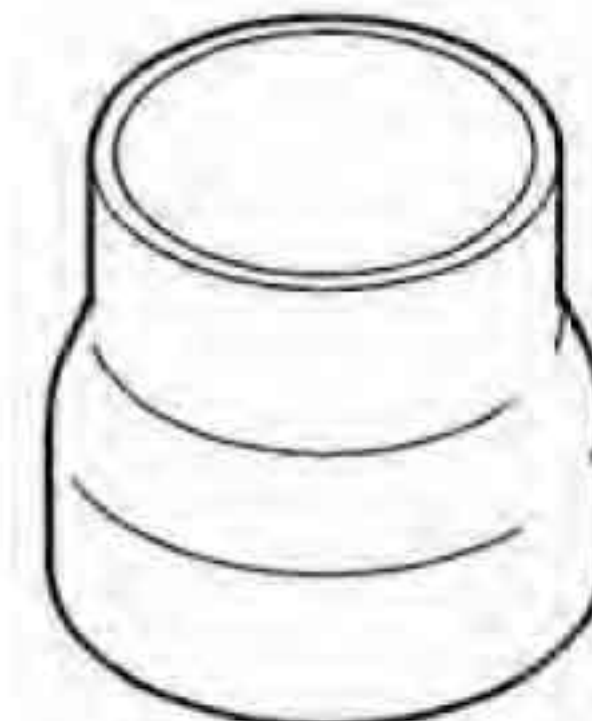

28, 29



30~34

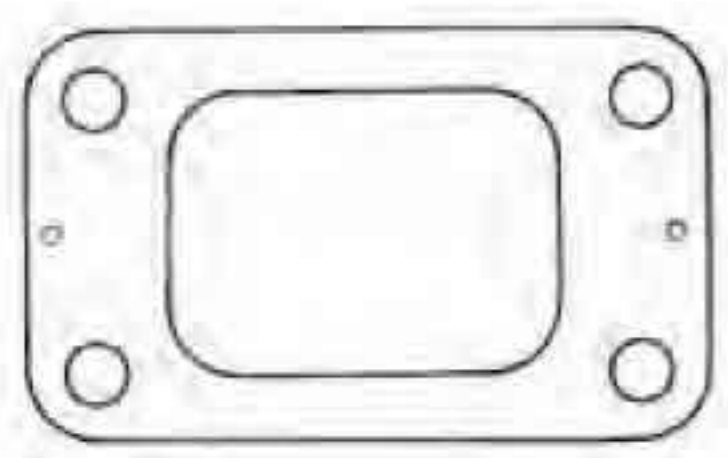

35

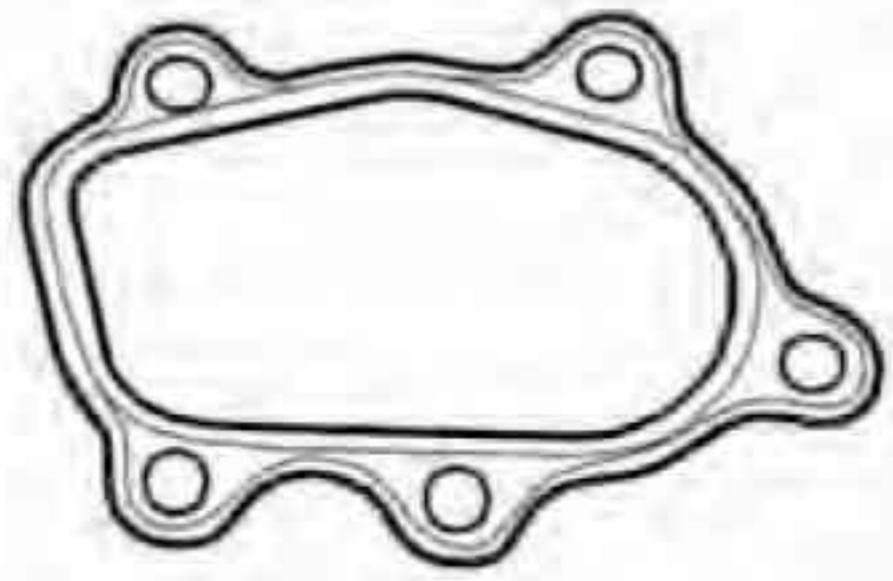

36



37

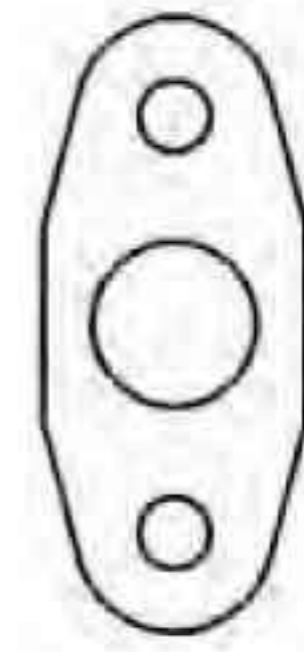

38



39

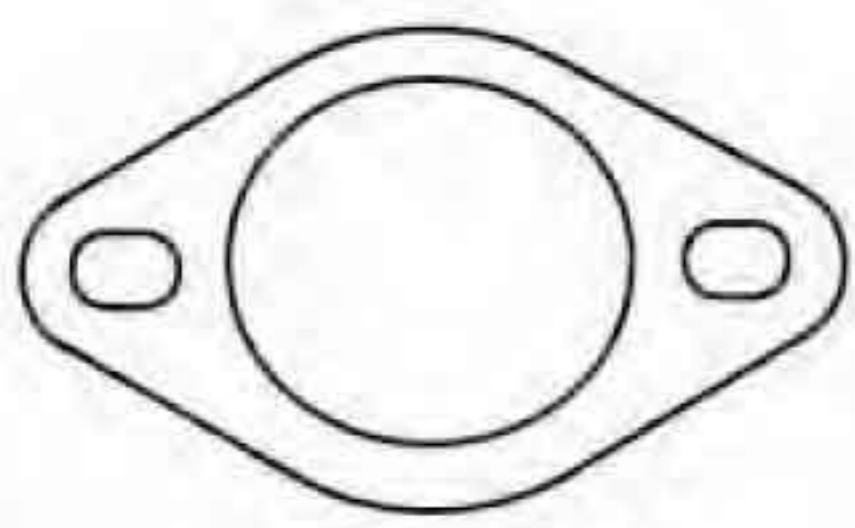

40



41



42

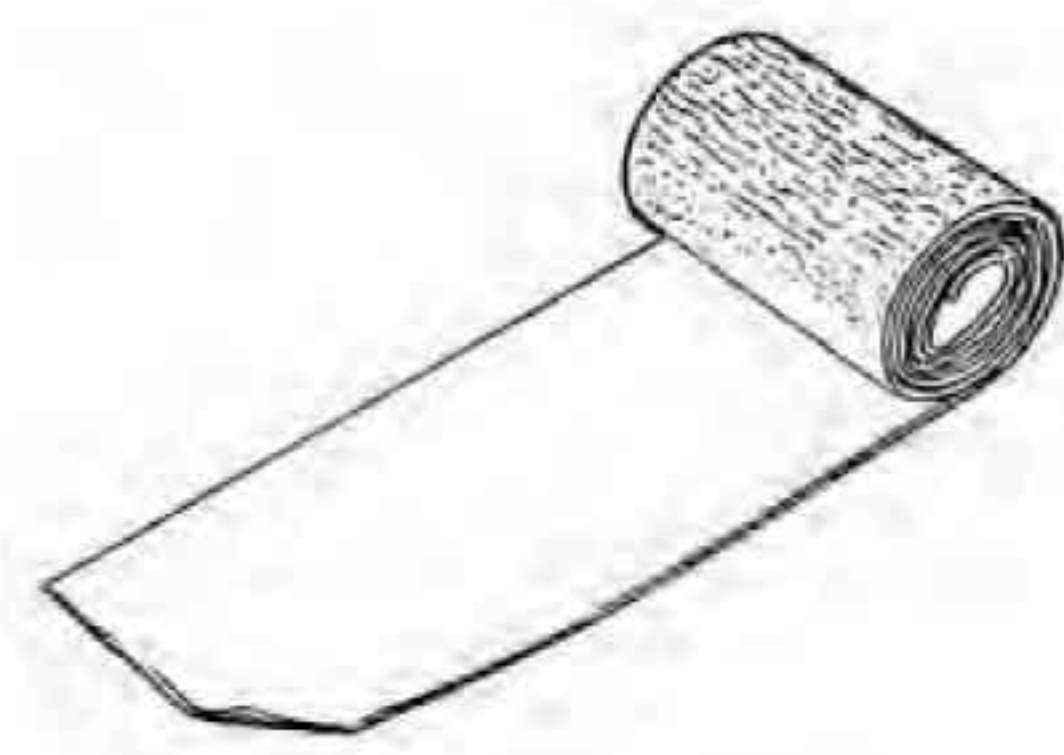

43



44



45



46



47



48



49



50



51



53



55



56



57

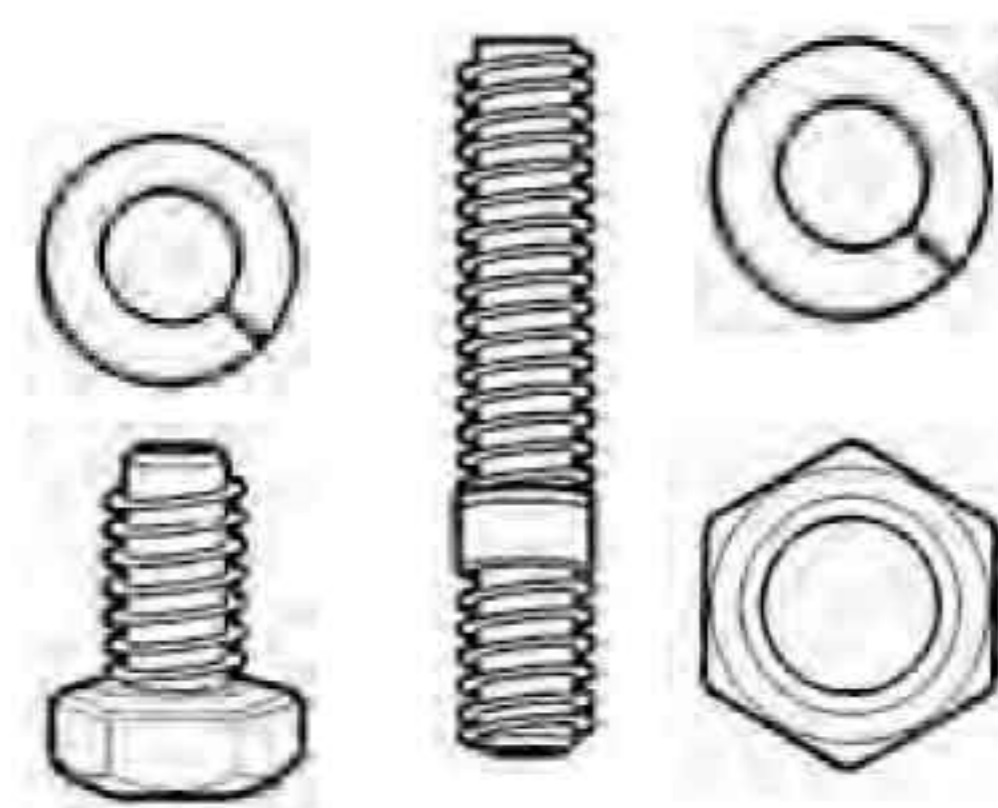

58~67



68

2. Removing OEM Parts

Refer to the factory service manual prior to the removal of OEM parts.

- 2-1 Disconnect the negative battery terminal.
- 2-2 Remove the under-cover, front bumper cover.
- 2-3 Remove the washer tank.
- 2-4 Remove front bumper reinforcement.
- 2-5 Remove the exhaust manifold.
- 2-6 Remove the air cleaner case assembly.
- 2-7 Remove oil pan.
- 2-8 Remove the oil pressure switch.
- 2-9 Remove engine oil pan (Sub Assembly No2).
- 2-10 Remove the intake chamber Assembly from the L Joint (below the brake booster).
- ※ Install the 5mm silicon cap to the L-shaped joint pipe.
(note: RHD photo shown)

〈Part # 21, 44〉



- 2-11 Remove the air cleaner inlet assembly and radiator cover plate.
- 2-12 Remove the radiator support sub assembly.
- 2-13 Remove the radiator fan, radiator fan shield and radiator reservoir tank..

3. Turbo Kit Mounting

3-1 Oil return tube positioning

(1) Clean and Drill a 13mm hole into the oil pan location shown in the diagram

※ Thoroughly re-clean pan before installation.



Be sure to wear eye protection when cutting and drilling is performed



(2) Install the stud bolts and heat shield onto the turbo manifold.

※ Install 3 stud bolts via white arrows.

〈Part # 2, 42, 56, 65〉

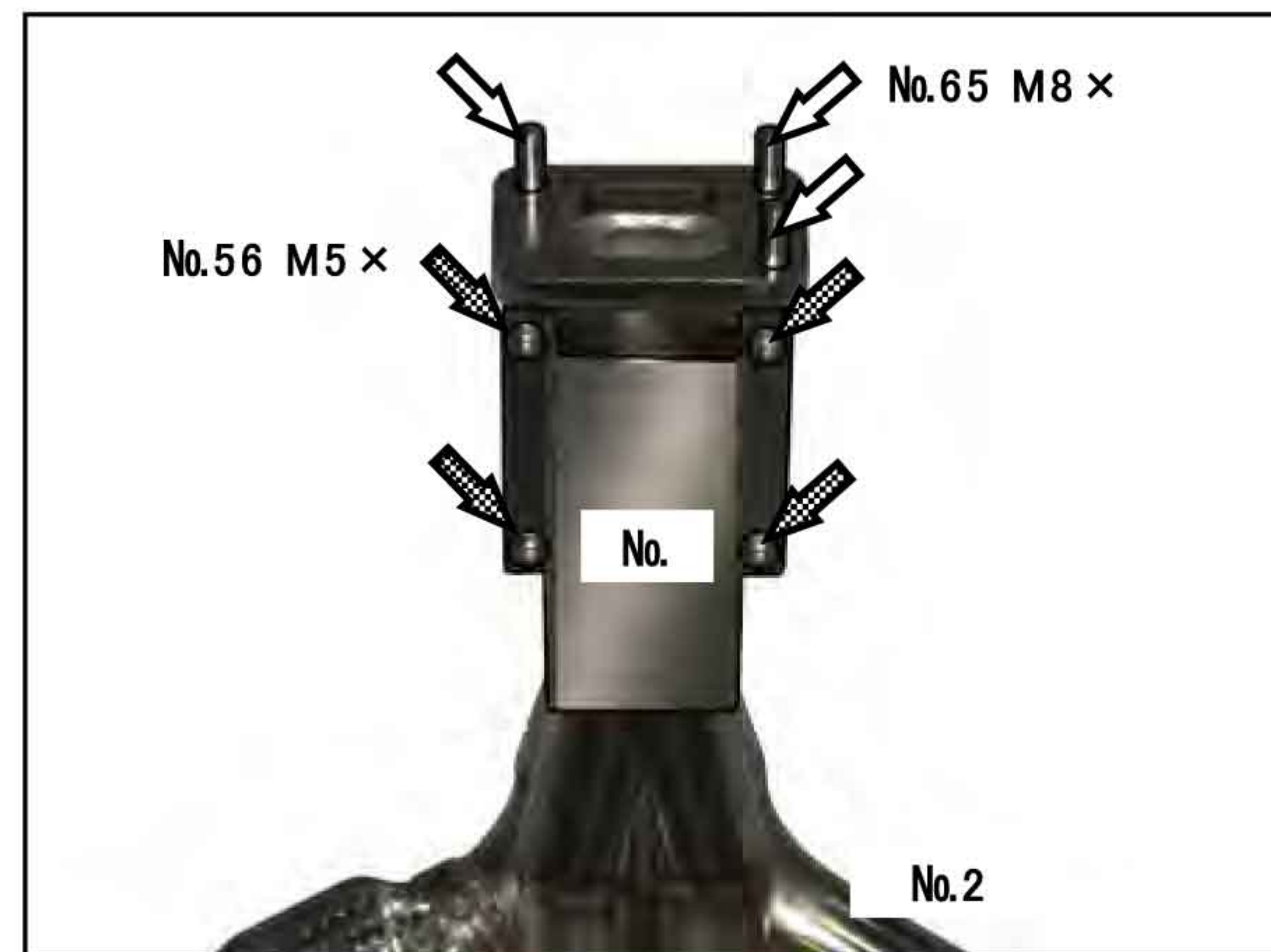

(3) Temporarily install the oil pan, turbo manifold and gasket.

※ This to aide in marking the Location for the oil return tube.

※ 〈Part # 39〉



Install the oil return tube and gasket onto the turbo.

〈Part # 1, 17, 38, 58〉

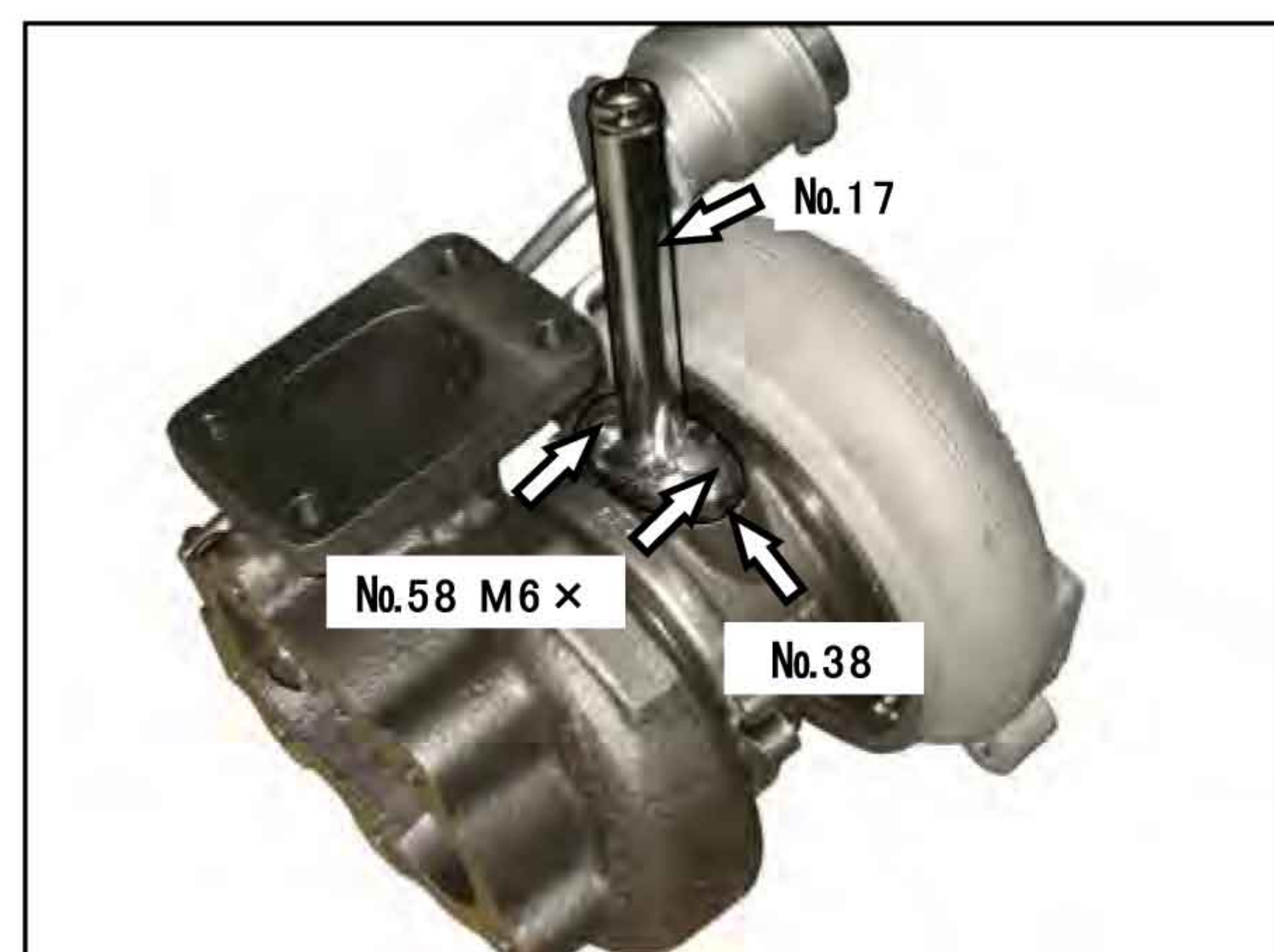

(4) Temporarily install the turbo and gaskets using the OEM bolts.

〈Part # 35, 64, 65〉



(5) Install the oil return hose bracket using the OEM bolt shown via white arrow.

〈Part # 49〉



(6) Mark the oil return tube in order to have the correct positioning.

※ Be sure that the oil return tube does not touch the crank pulley, and that it is aligned with the oil return hose bracket.

〈Part # 18, 24〉

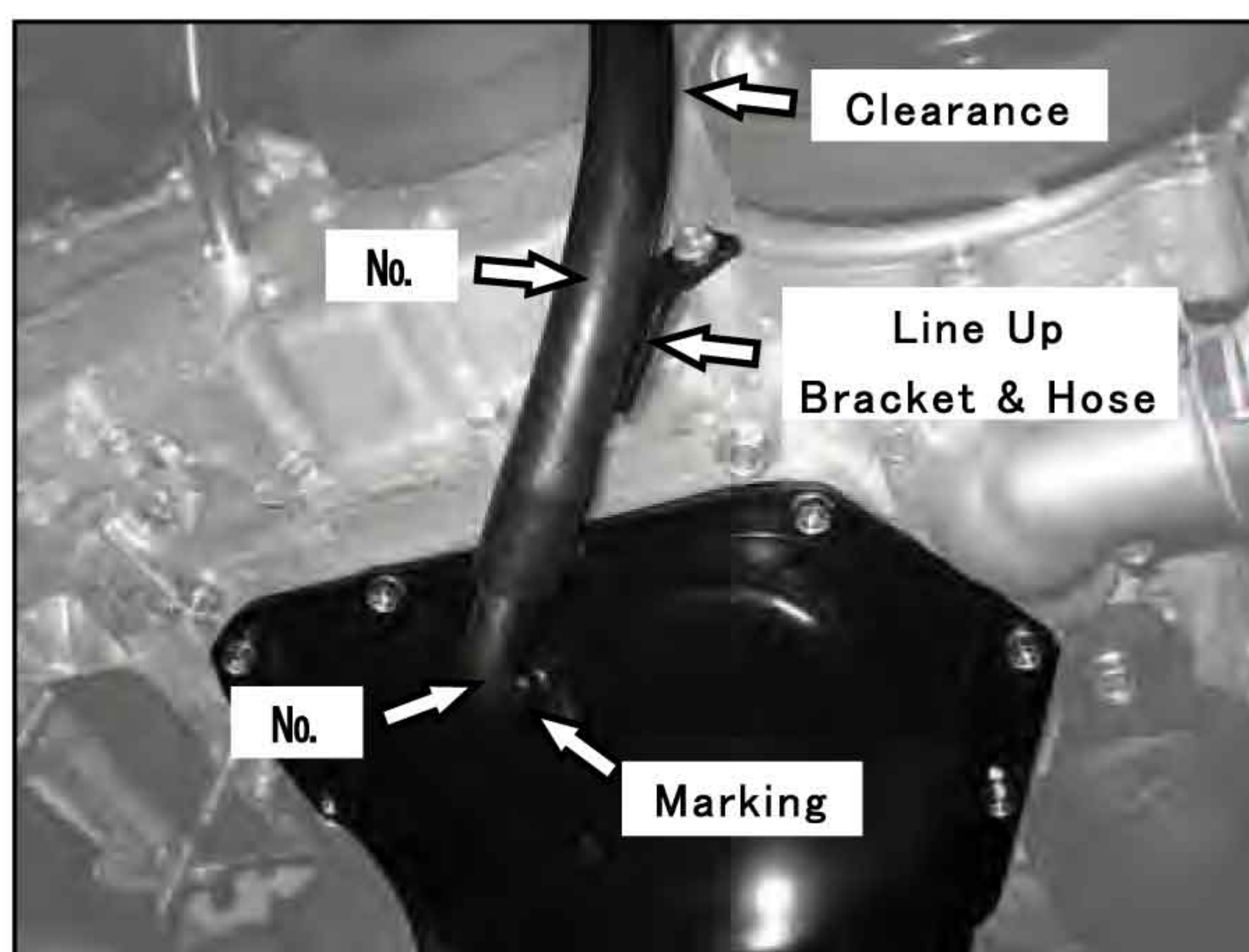

3-2 Oil Pan Tapping

(1) Remove the turbo charger, turbo manifold, gaskets and oil pan.

(2) Weld on the oil return tube using the Location & Positioning markings that were marked previously.



Be sure to wear protective goggles and gloves when welding.
After welding, we recommend painting the surface to prevent rust.



〈Parts No.18〉

3-3 Installation of Oil Pan

Re-Install oil pan.

※ Use liquid gasket.



3-4 Replace Stock Radiator Fans

(1) Unplug and remove factory OEM radiator fans.

(2) This kit requires the use of aftermarket low-profile electric fans.

* Recommended Fans or Equivalent

2x Spal Low Profile 9" Fans

p/n 30100381



※ Change the location of the radiator fan harness and wrap with thermo wrap.
thermo wrap.
wrap.

〈Parts No.43, 44〉
3, 44〉

(3) Reinstall new low profile radiator fans.

new low profile radiator fans.

profile radiator fans.

radiator fans.

fans.

(4) Install reservoir tank brackets (Check with reservoir tank,
reservoir tank brackets (Check with reservoir
tank, then remove tank)

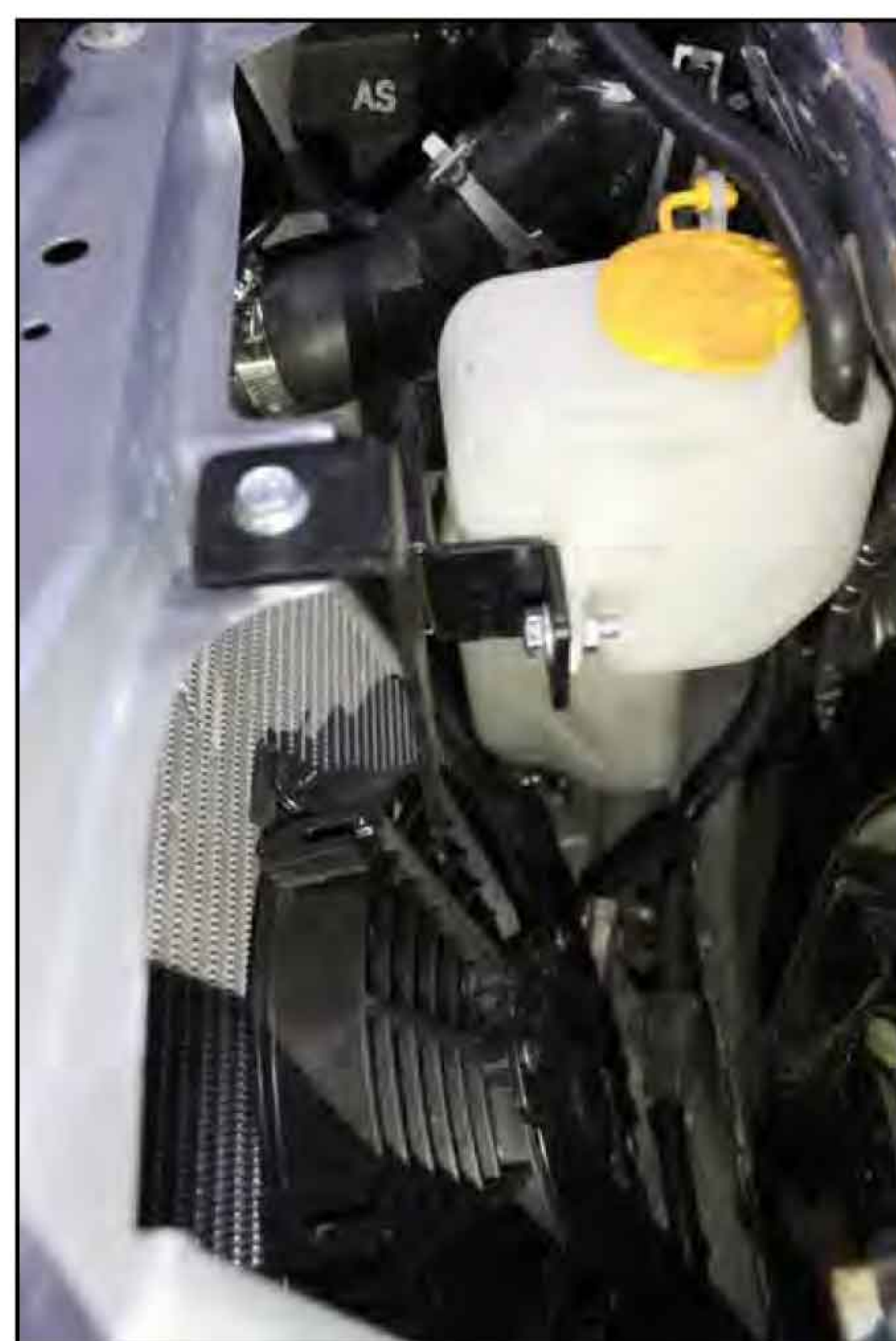

(Part No. 53)

3-5 Turbo Manifold Installation

- (1) Wrap the lower radiator hose with thermo wrap as shown in the diagram.

〈Parts No.43〉

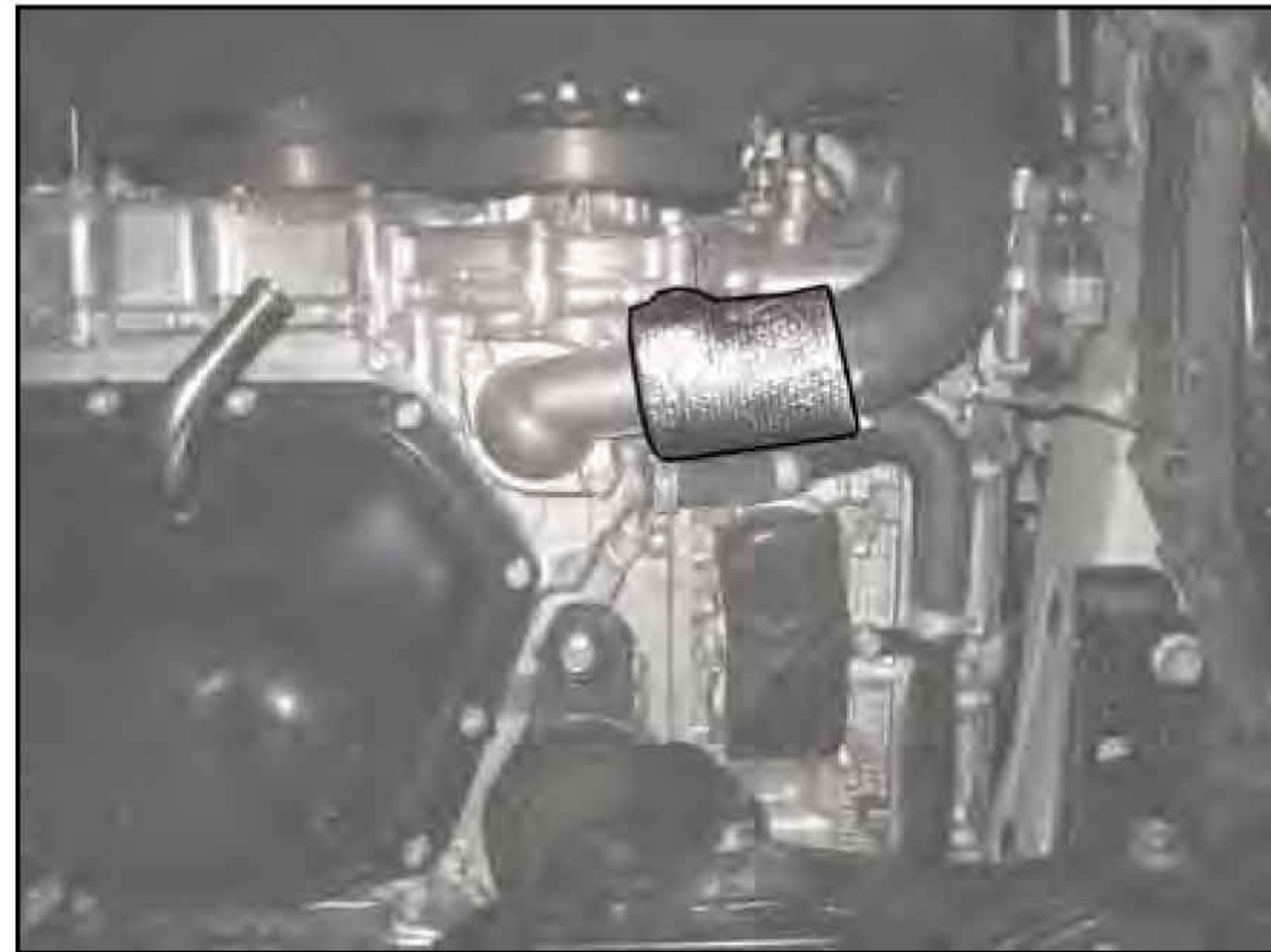

- (2) Install turbo manifold and test pipe bracket.

※ Be sure to purchase new replacement nuts from the dealer. Do not re-use original nuts.

Toyota SU003-02873

Subaru 902370010

〈Parts No.2, 39, 50〉

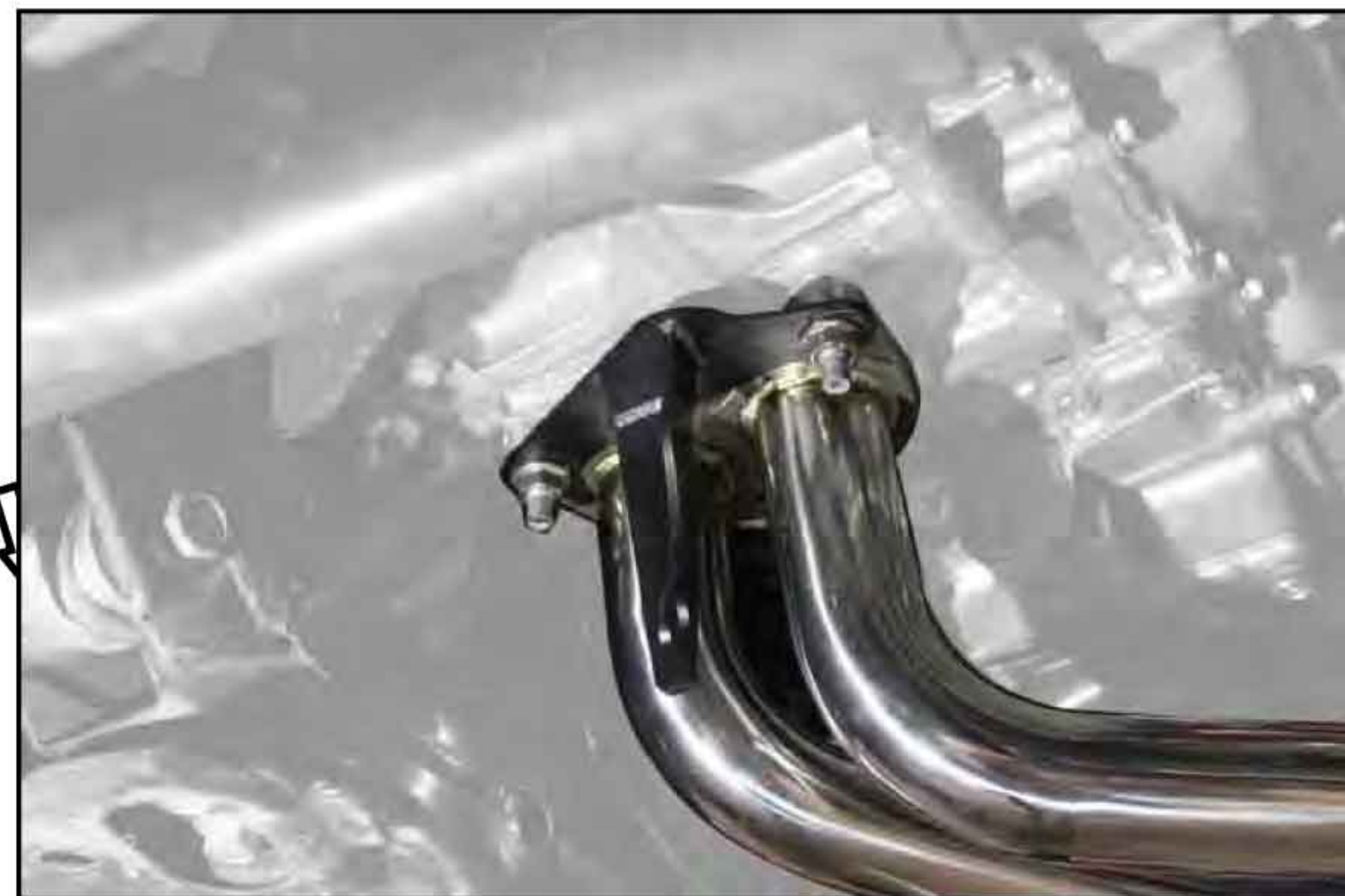

3-6 Installation of Turbo Charger

- (1) Loosen the tensioner pulley by turning the bolt head clockwise. Insert pin or hex key into the orifice to keep tension off of the pulley as shown via white arrow.

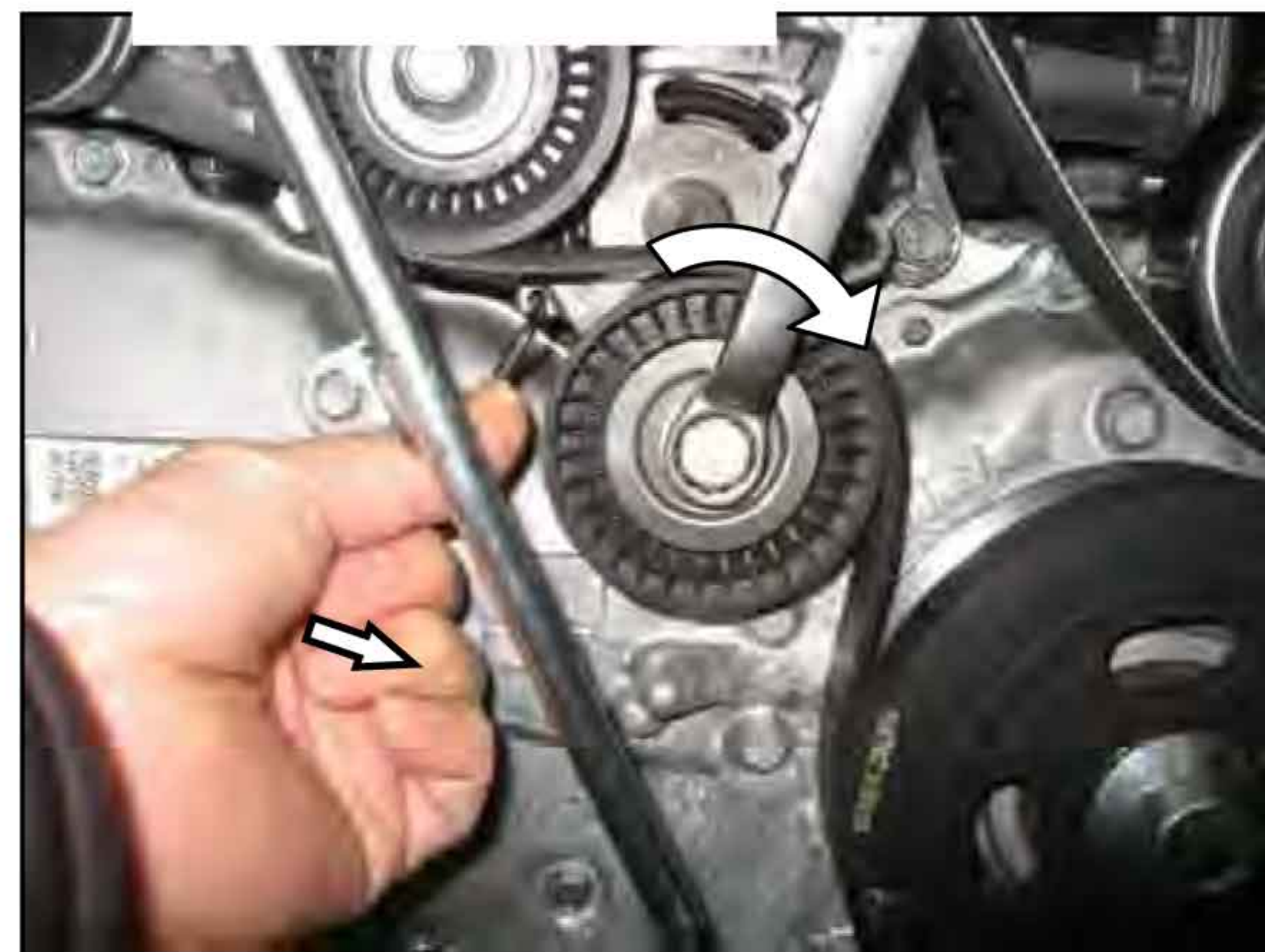

Remove the Idler pulley's 1 & 2.



- (2) Install the Turbo Mounting Bracket A. Using the Turbo Bracket to Pulley Spacers A & B, ○
※ Turbo Bracket to Pulley Spacers A has a lip, be sure that this lip is inserted into the Idler Pulley.

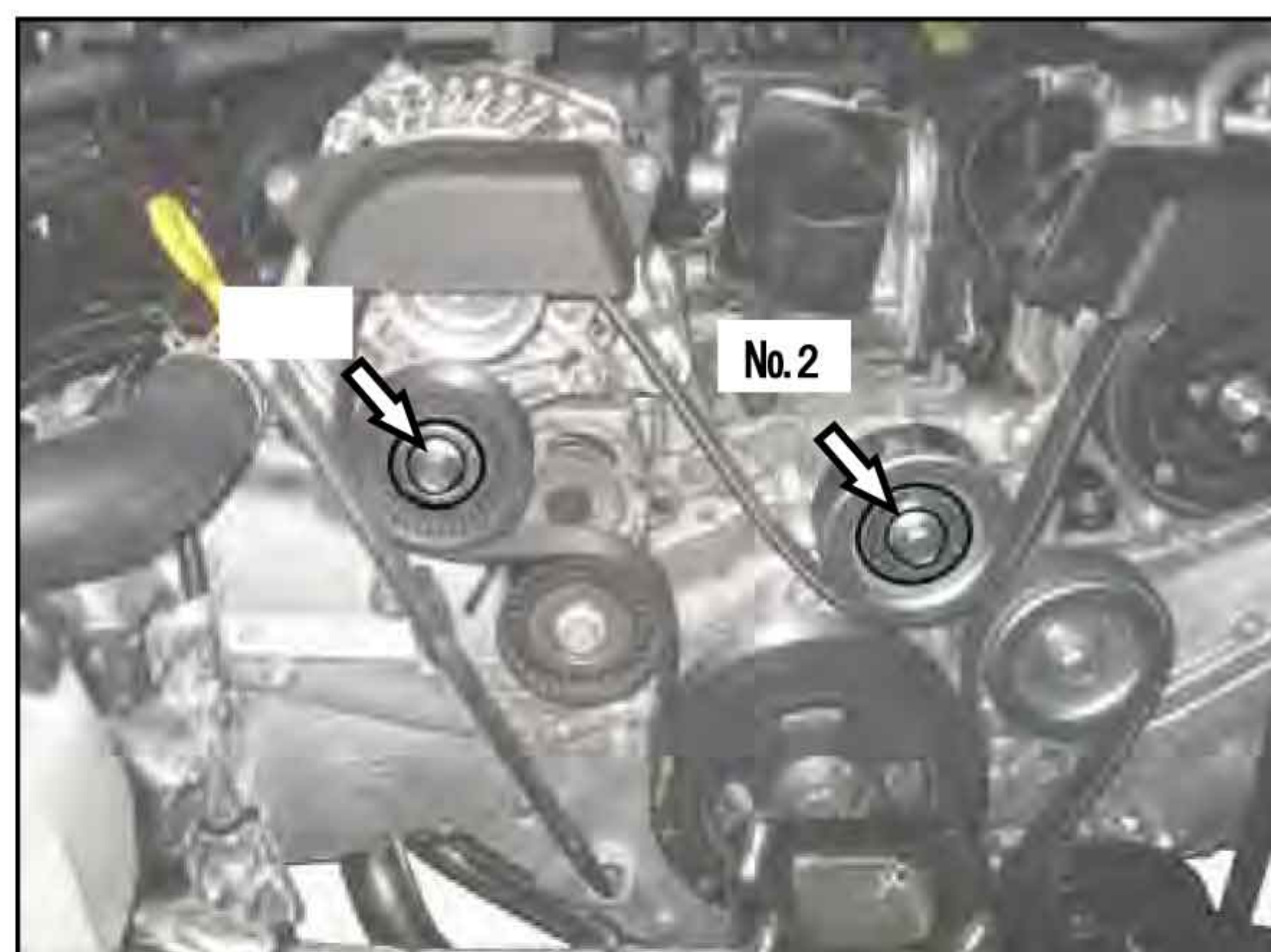

※ When installing the Turbo Mounting Bracket, be sure to not remove the serpentine belt.

Pulley Bolt Torque Specs 36Nm (3.67kgf-m)
〈Parts No.45, 47, 48, 68〉

(3) Verify that the serpentine belt is seated on each pulley, from then on release the tensioner pulley.

(4) Install the Turbo assembly, and install the turbine inlet gasket.

〈Parts No.1, 35, 64, 65〉

3-7 Three Way Oil Fitting

(1) Install 1/8PT- 1/8PT Straight Union into the Three Way Fitting as shown in the diagram.

※ Be sure to use thread seal.

※ Too much thread seal or an excess of thread seal may lead to oil feed blockage.

※ Be sure not to over tighten the straight union fitting .

〈Parts No.14, 15〉

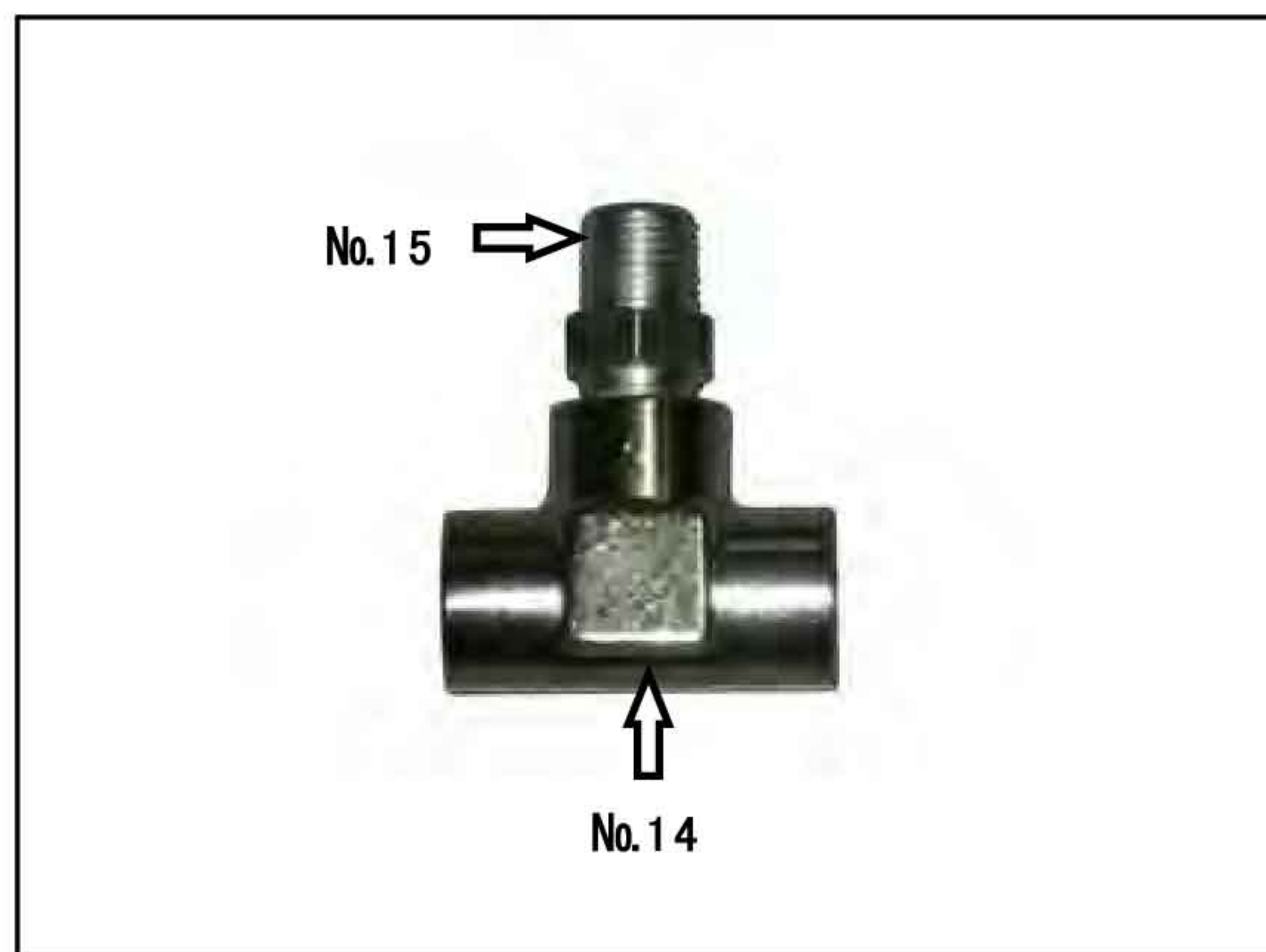
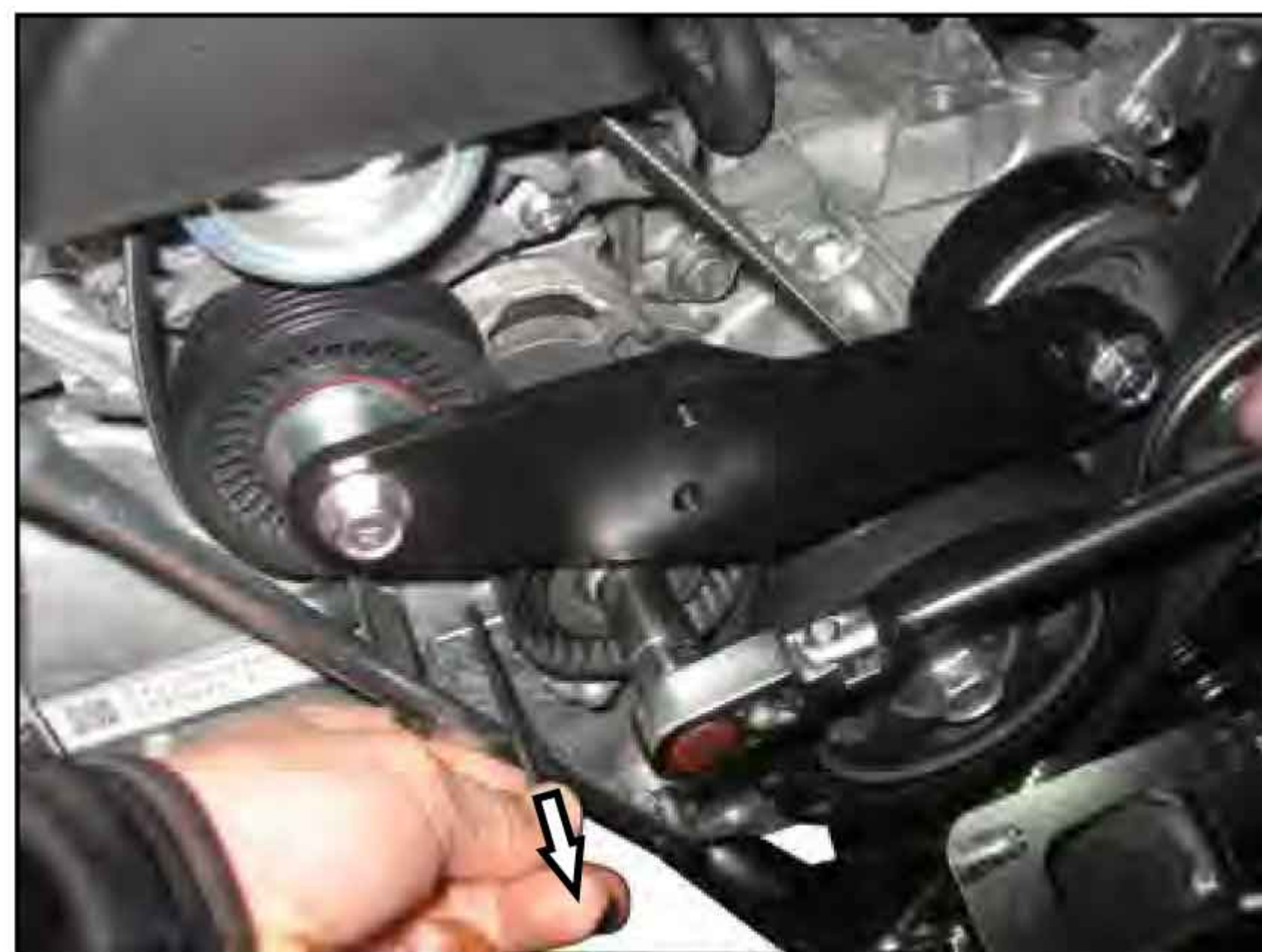
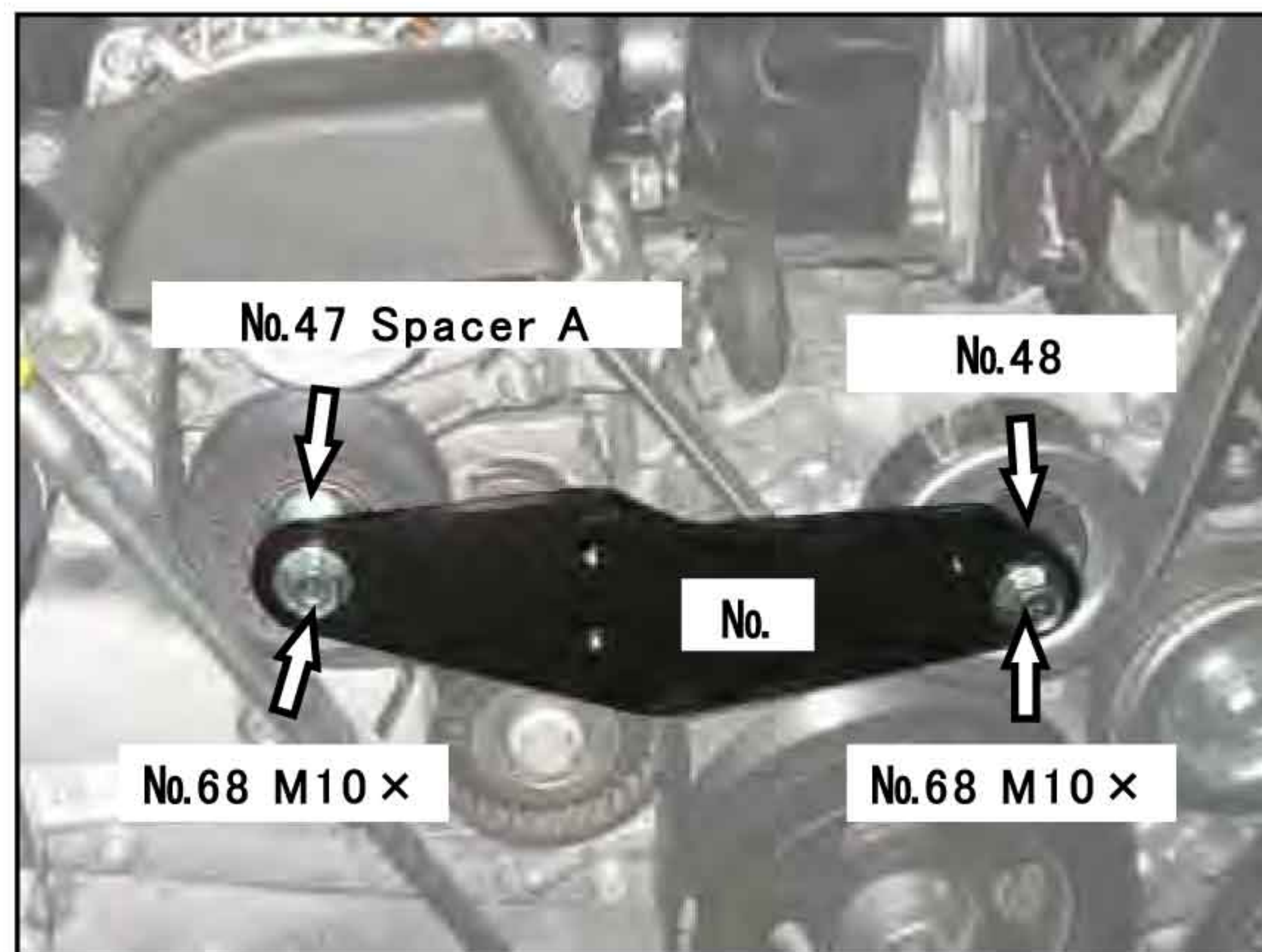

(2) Install the factory oil switch onto the 3-way fitting as shown in the diagram.

※ Be sure to use thread seal.



(3) Install the 1/8NPT - -3 straight fitting on the opposite side of the Oil Pressure Switch as shown in the diagram.

※ Insert 1/8NPT portion in to the 3 way fitting.

※ Be sure to use thread seal.

〈Parts No.16〉

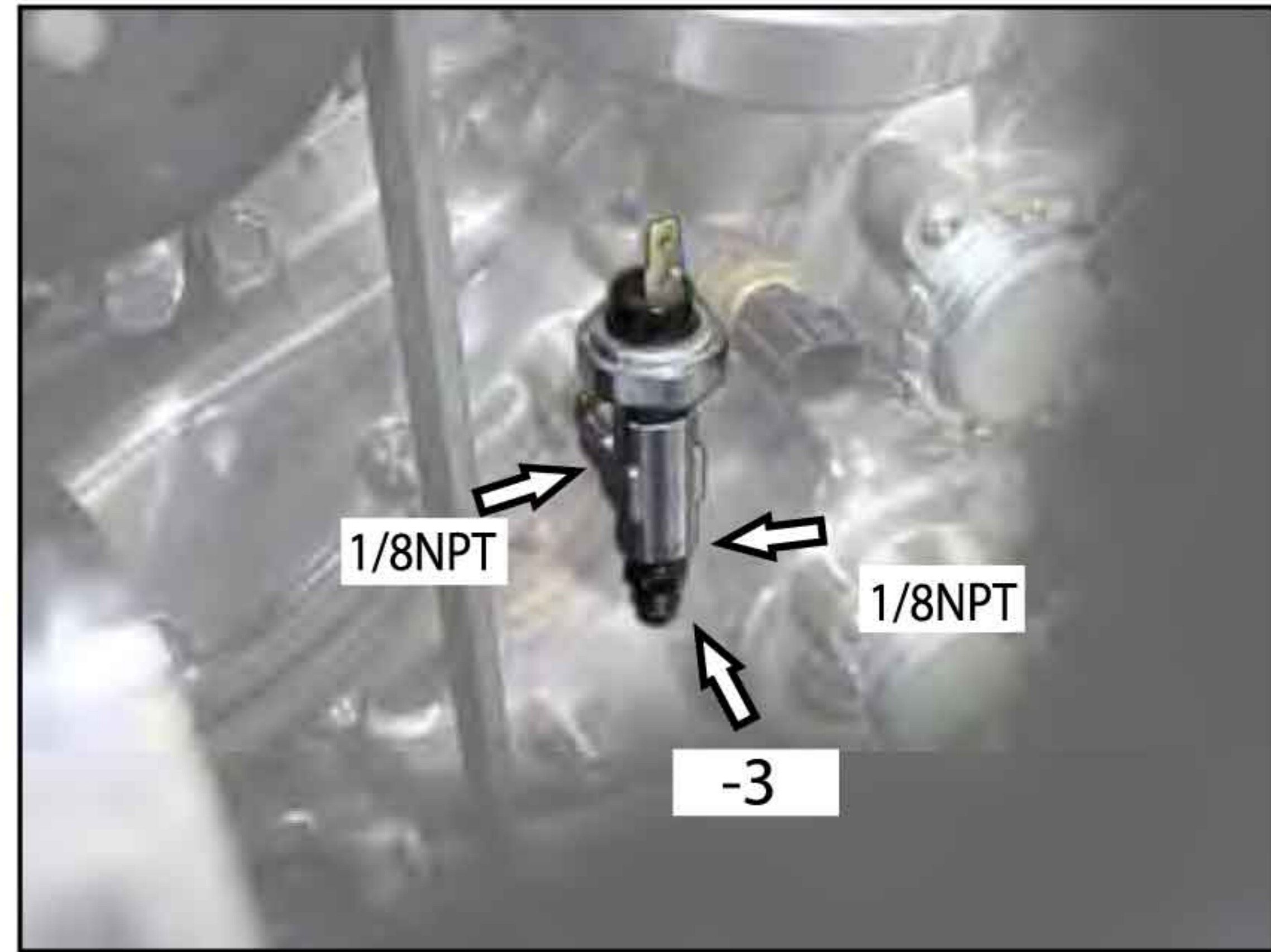

(4) Reconnect the Oil Pressure Switch Harness.



(5) Install the Banjo Bolt and crush washer as shown in the diagram.

※ Be sure that the oil line side faces towards the front of the vehicle.

	Oil leaks can cause engine bay fires that can lead to bodily harm. Be sure to install and secure the oil feed line .
--	--

〈Parts No.12, 13〉

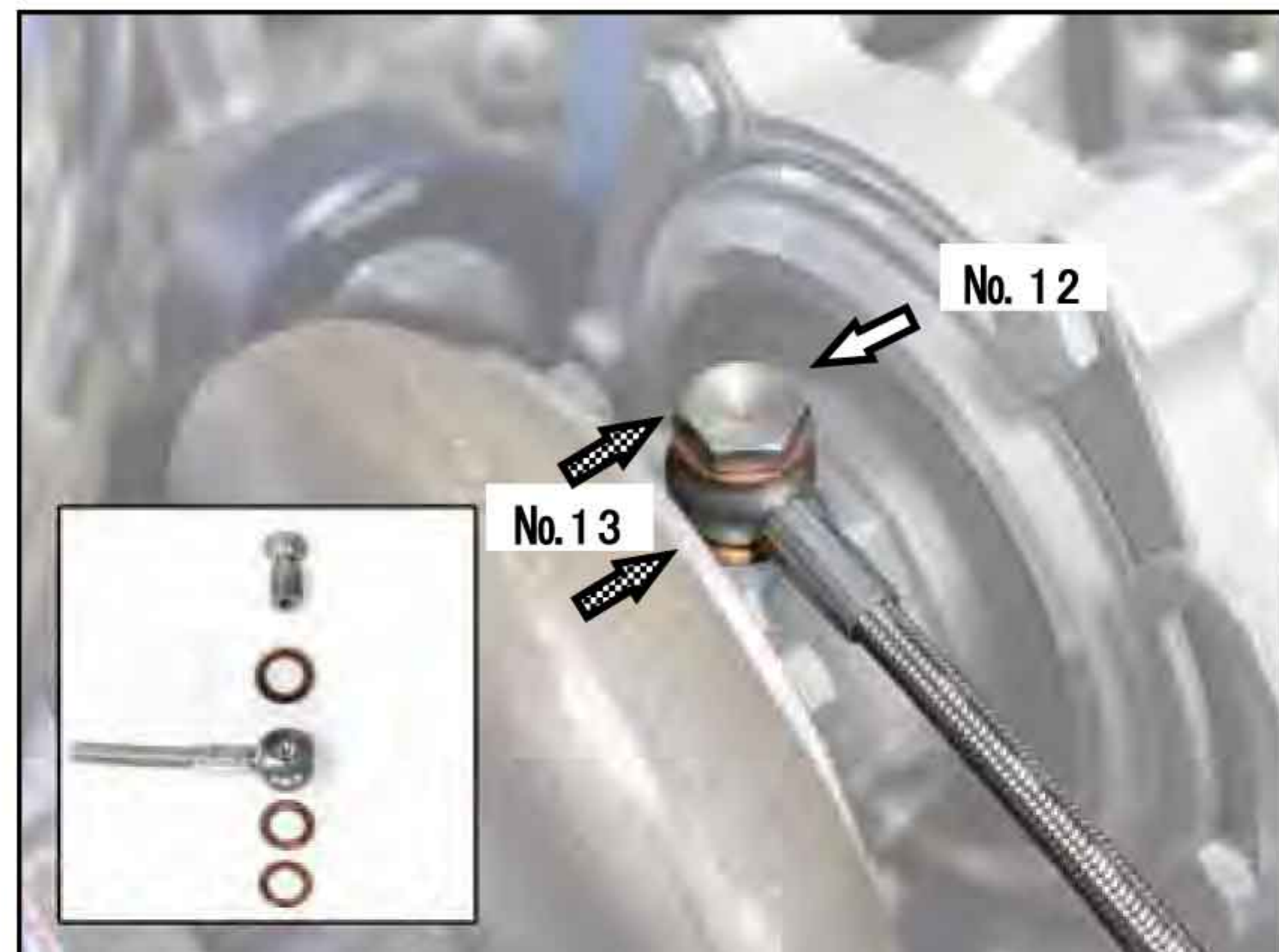

- (6) Install the Oil Pressure Line between the Banjo Fitting and 90 degree elbow. Mount the Oil Pressure Line to the core support or upper radiator, using supplied Zip Ties.

〈Parts No.11, 44〉

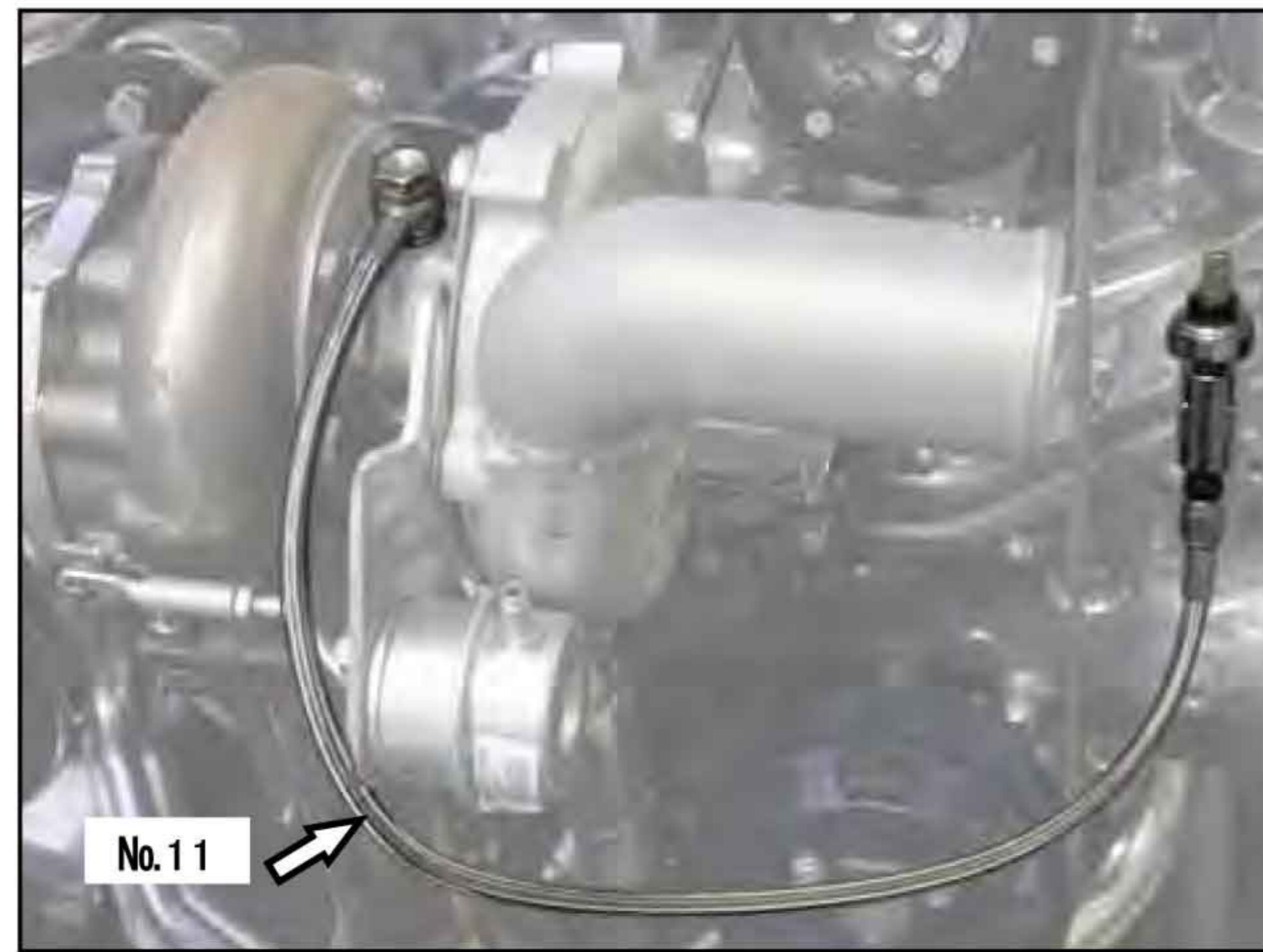

3-8 Oil Return Hose Installation

- (1) Route the Oil Return Hose between the Turbo and Oil Pan wrapped in thermo cloth.
- ※ Completely wrap the hose with thermo cloth make sure there are no exposed areas.

〈Parts No.24, 31, 43〉

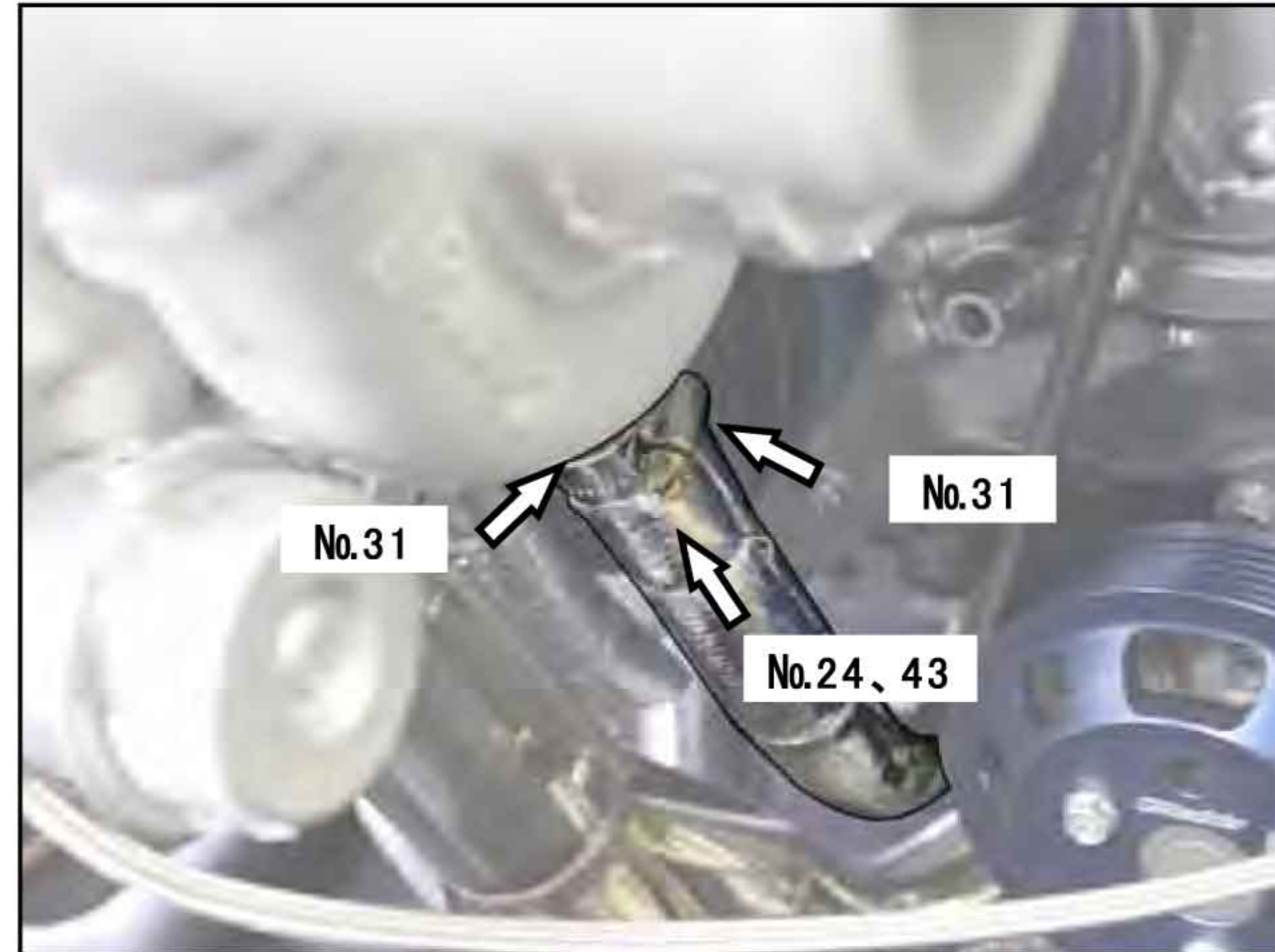

- (2) Mount the Oil Return Hose to the Oil Return Hose Bracket. We recommend using stainless steel wire.



3-9 Turbo Water Line Installation

(1) Remove OEM “No.2 Water By-Pass Hose” by disconnecting it from the side of the Throttle-body and at the Heater-Pipe Assembly (at the back of the engine.)

(2) Replace the hose with provided 3’8” water hoses as shown below in the diagram.

- ❖ Throttle-body to backside of the turbo.
- ❖ Heater-hose to the front of the turbo.

〈Parts No.25, 37, 30〉

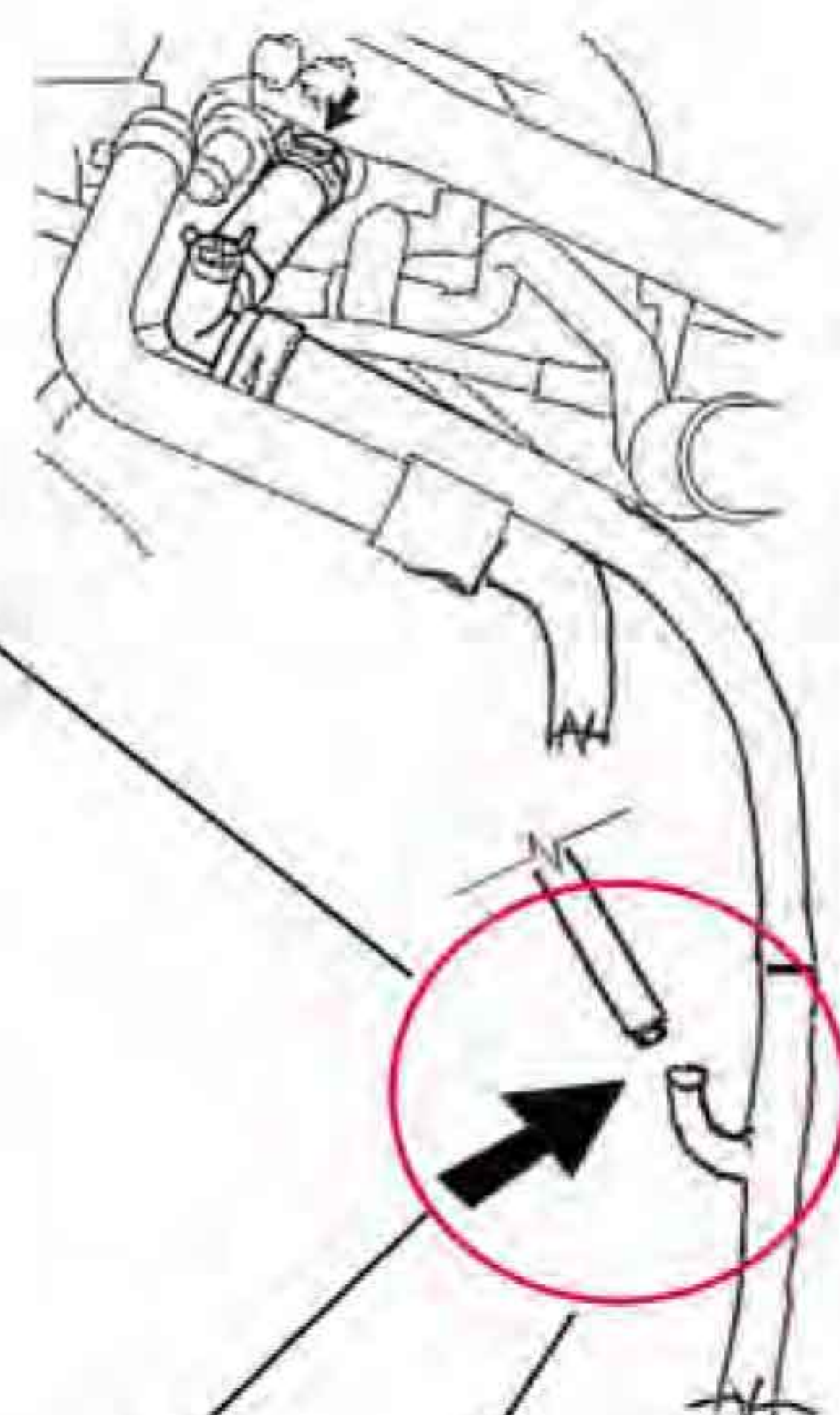
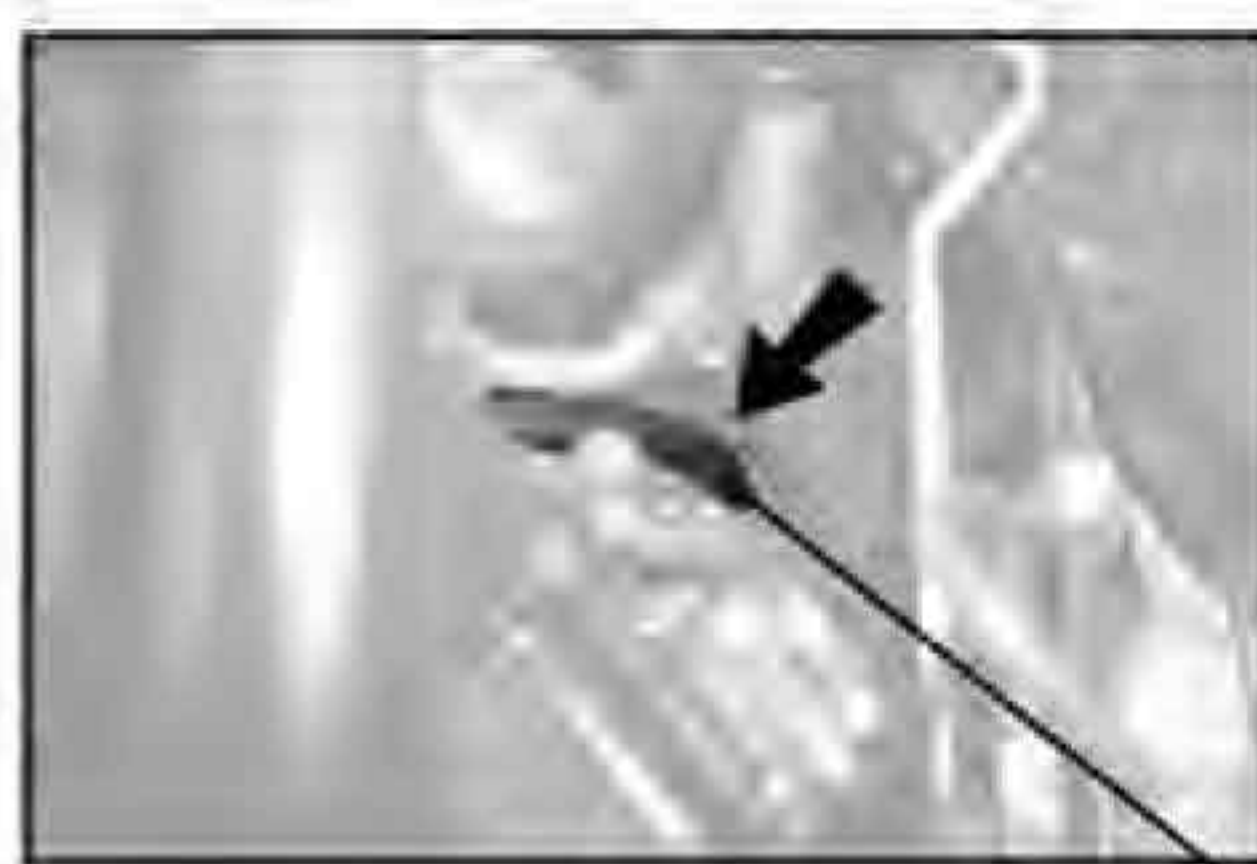
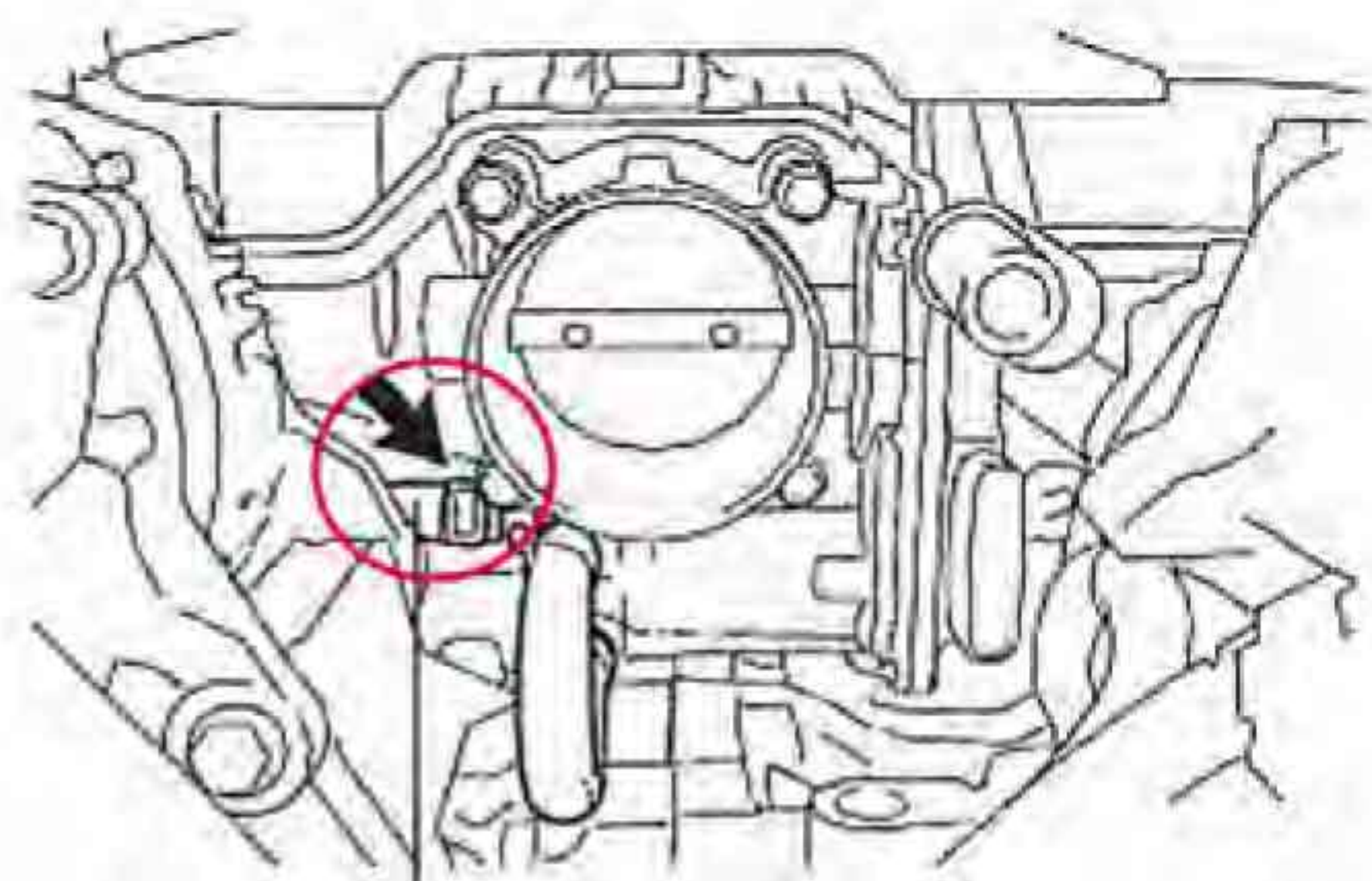

HEATER PIPE ASSY.

REMOVE No.2 WATER BY-PASS HOSE
(ON THE SIDE OF THE THROTTLE BODY)

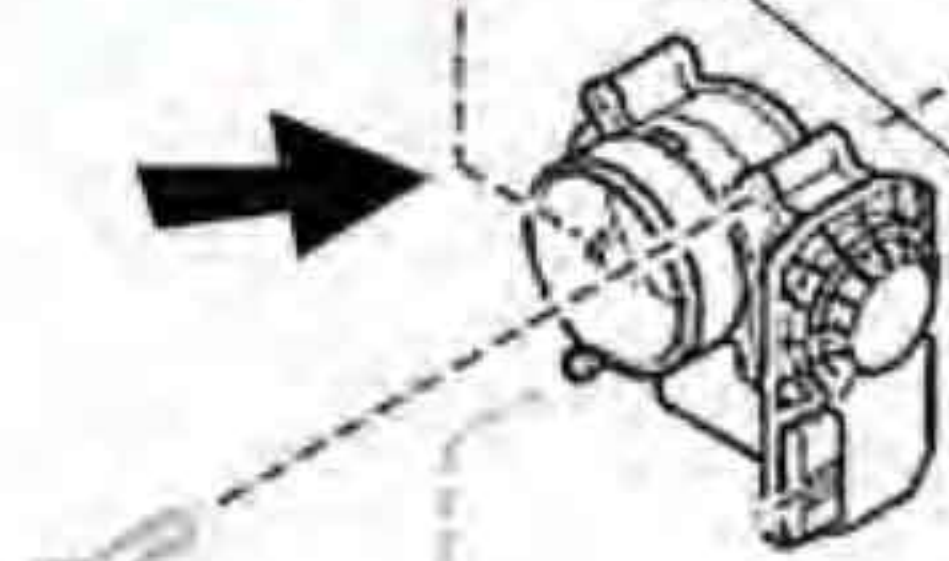
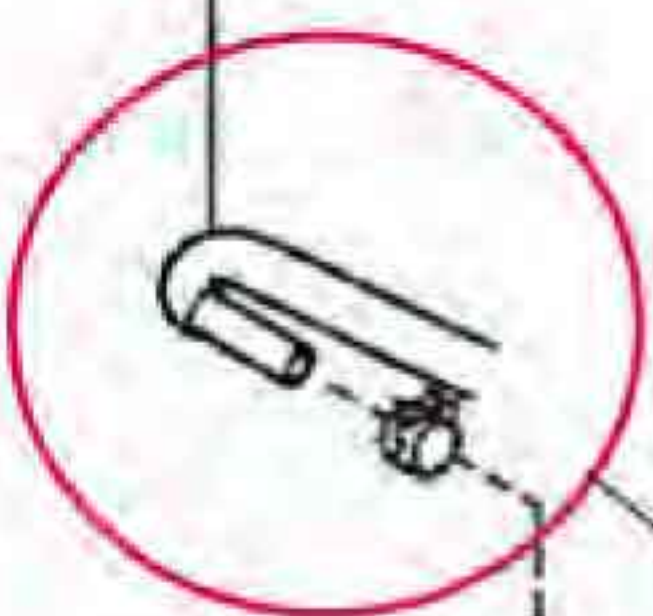

GASKET

NO.1 WATER BY-PASS HOSE
(DO NOT REMOVE THIS HOSE)



AND REPLACE WITH TURBO WATER LINES AS SHOW ABOVE

3-10 Down Pipe Installation

- (1) Install the Down Pipe and Turbine Outlet Gasket using the supplied hardware in the orientation shown in the diagram.

〈Parts No.3, 36, 66〉



- (2) Wrap the Air/Fuel Sensor Harness with thermo cloth.

〈Parts No.43〉

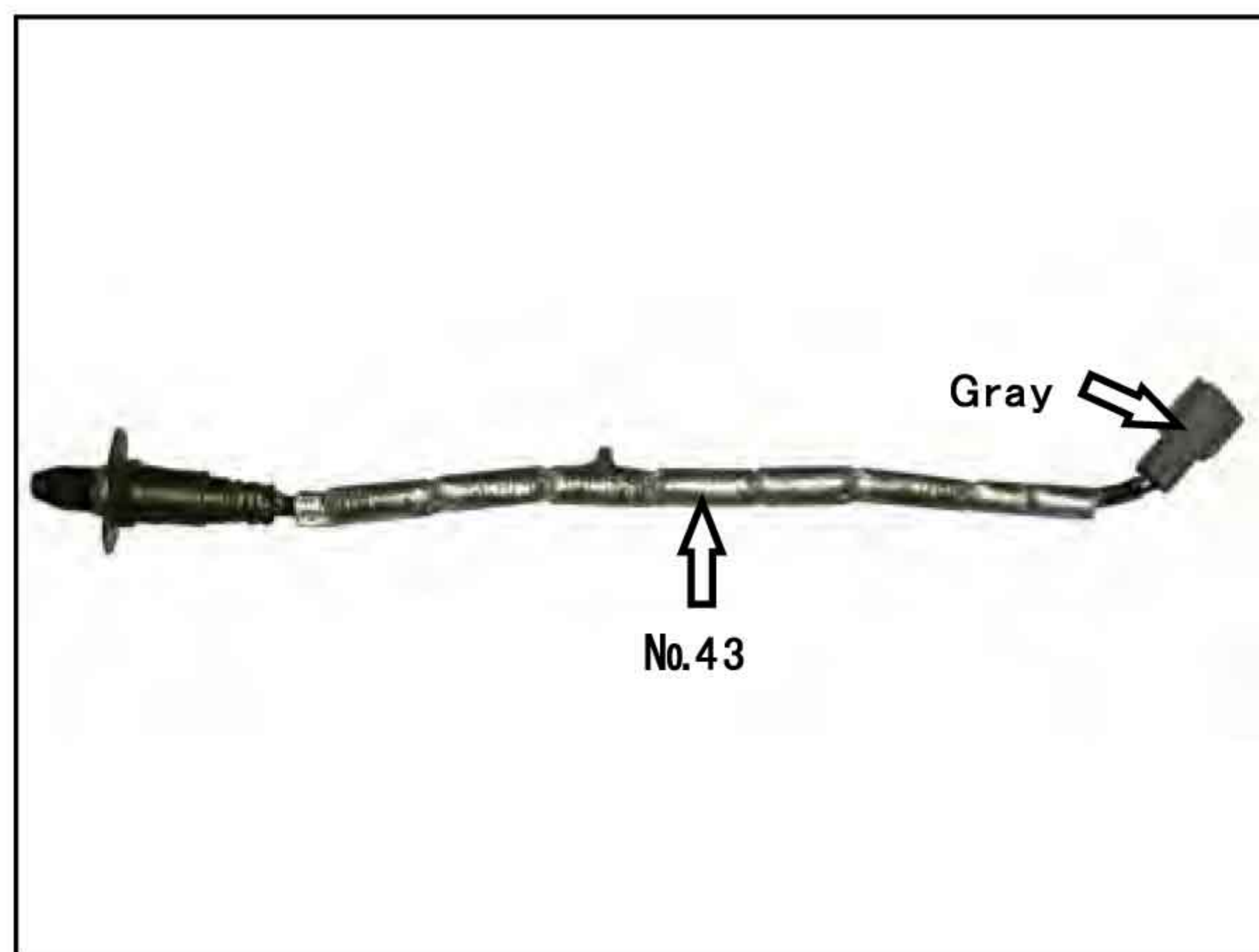

- (3) Install the O2 and Air Fuel Sensor onto the Test Pipe.

〈Parts No.4〉

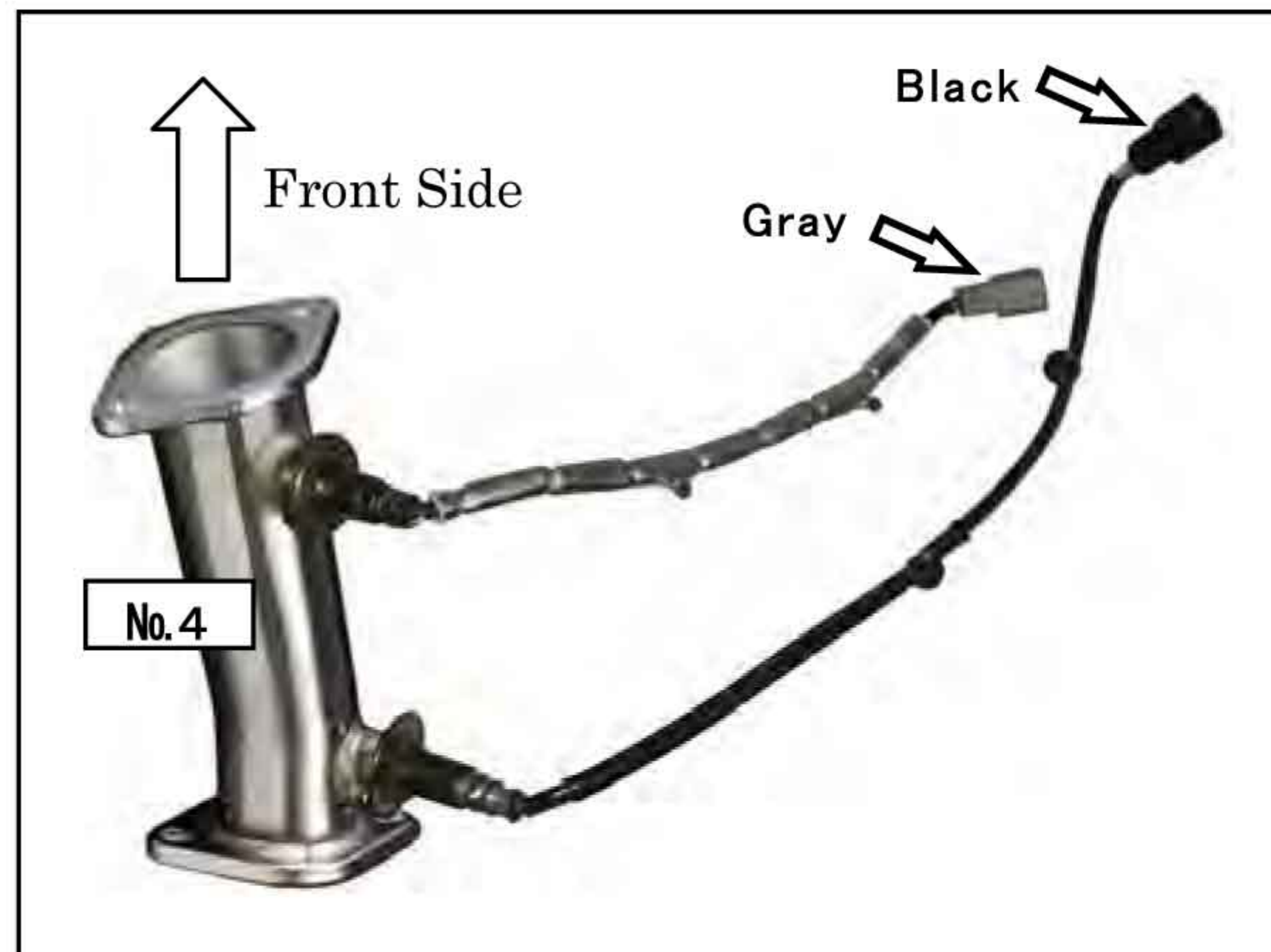

Install the Test Pipe using our gaskets and hardware.

- ※ Be sure to readjust or make adjustments to the exhaust system if needed.
- ※ This photo is for the JDM Turbo Kit only.

〈Parts No.40, 67〉



Install the Turbine Bracket B.

〈Parts No.46, 63〉

- ❖ Installation may require slightly prying the turbo away from the pulleys to line up the bracket bolt holes.

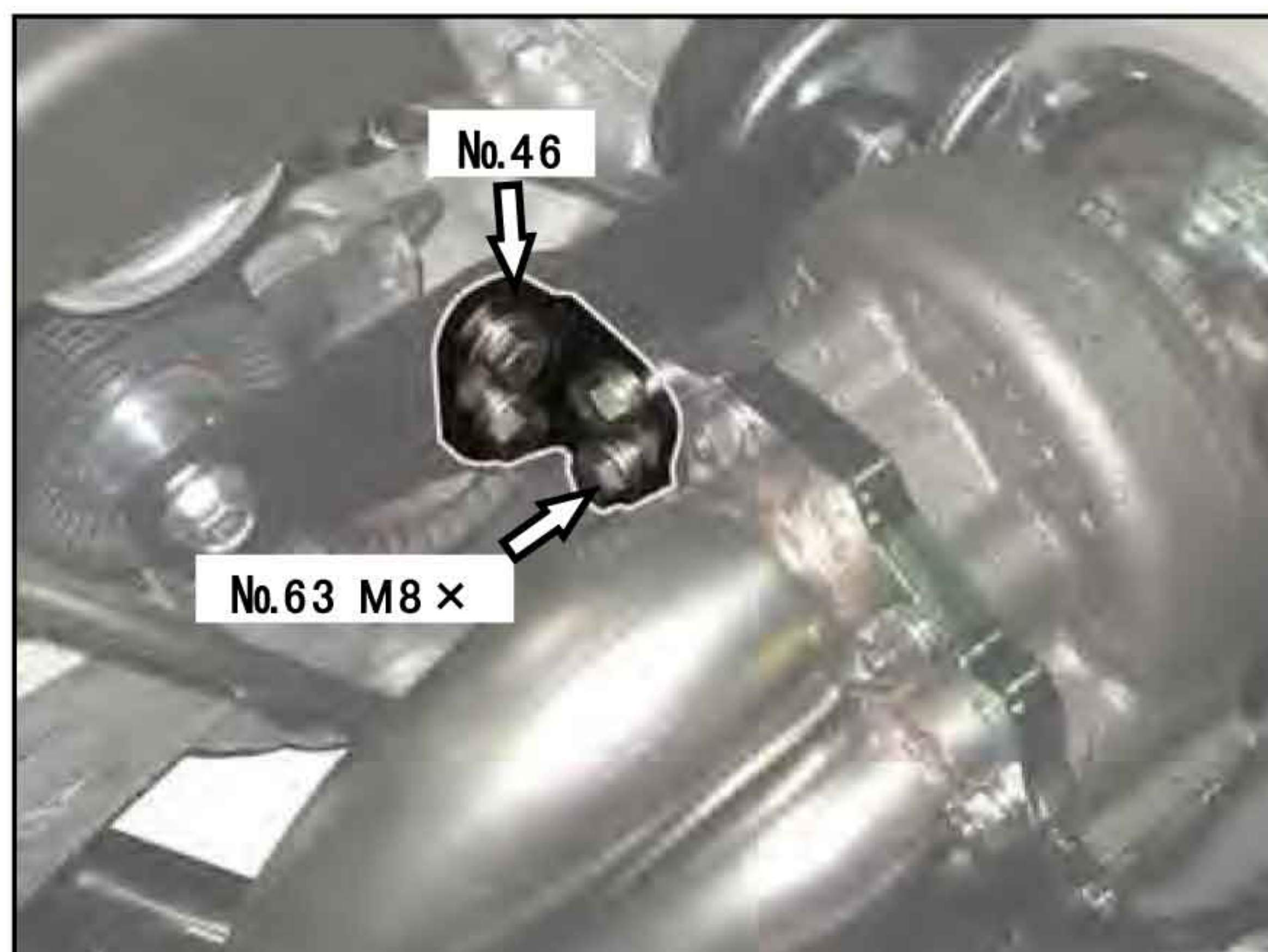

Readjust exhaust piping from the Turbine as needed, then tighten.

- (4) Reconnect O2 Sensor and Air Fuel Sensor harness couplers.



3-11 Heat Shield Installation

- (1) Install the Turbine Bracket A.

※ Temporarily finger tighten.

〈Parts No.57〉



- (2) Install the Turbine Heat Shield by sliding the cut outs over the down pipe hardware as shown in the photo.

〈Part No.41, 57〉

- (3) Tighten the bolts.

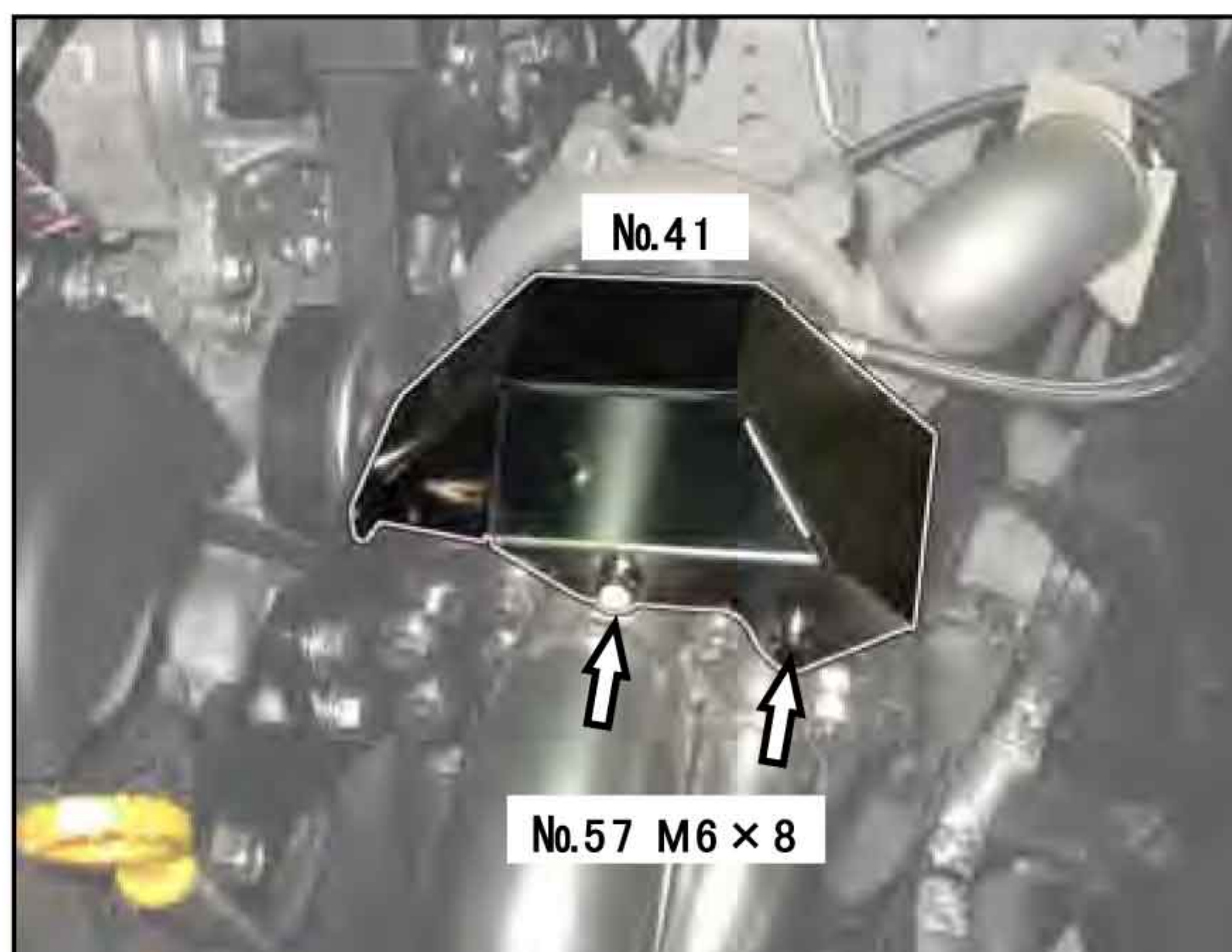

3-12 Intercooler Installation

- (1) Reinstall the radiator core support sub assembly.
- ※ Relocate the hood latch cable as shown in the photo. Use zip tie to mount the cable.

〈Parts No.44〉

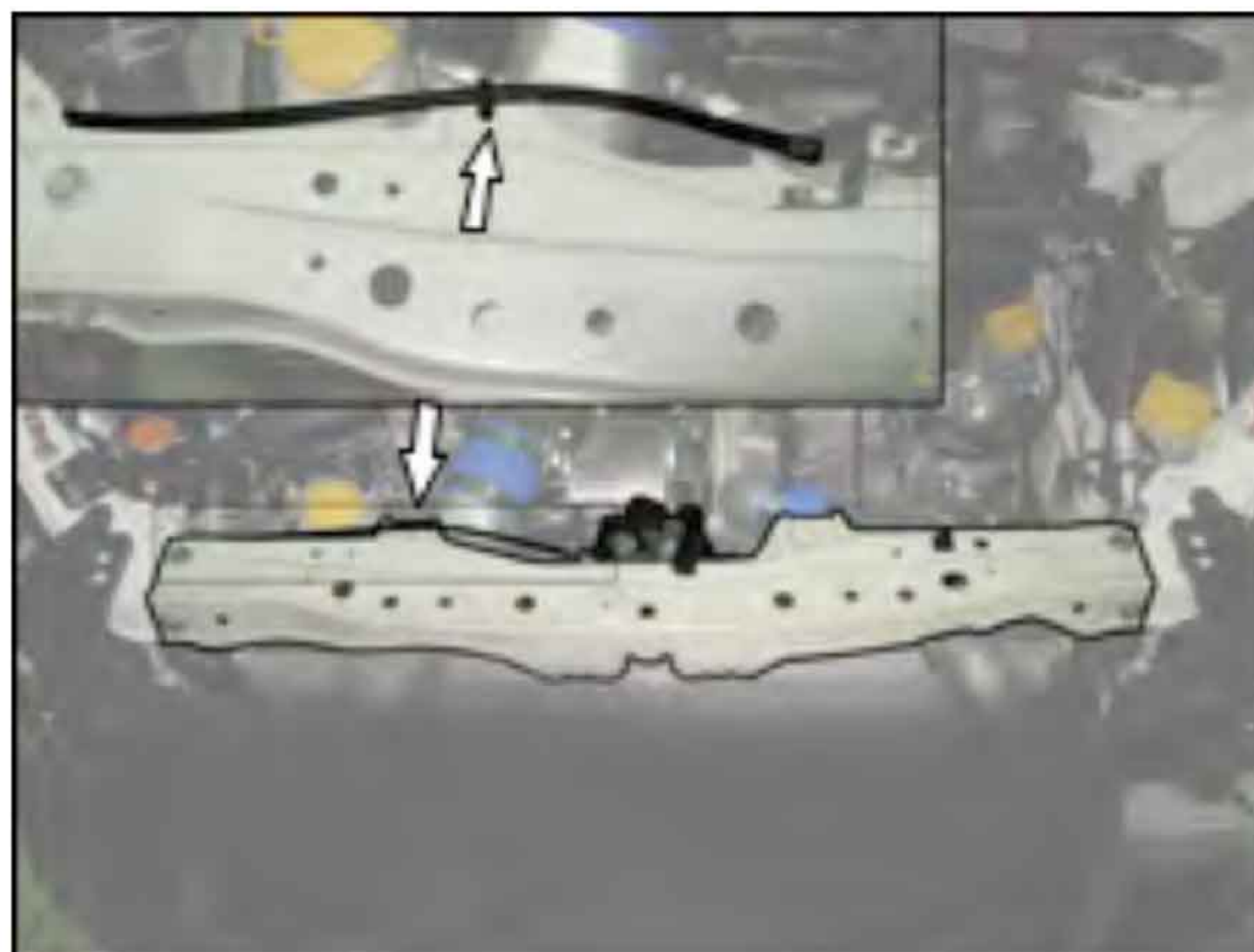

- (2) Install the Intercooler Mounting Bracket Temporarily Finger Tighten.

〈Parts No.51, 59〉



No.59 M6 × 15mm

(3) Remove the front bumper bracket and drill out two holes as shown in the diagram.



Be sure to wear proper eye protection when cutting or drilling.
Clean the surface area of any sharp edges and repaint exposed metal.

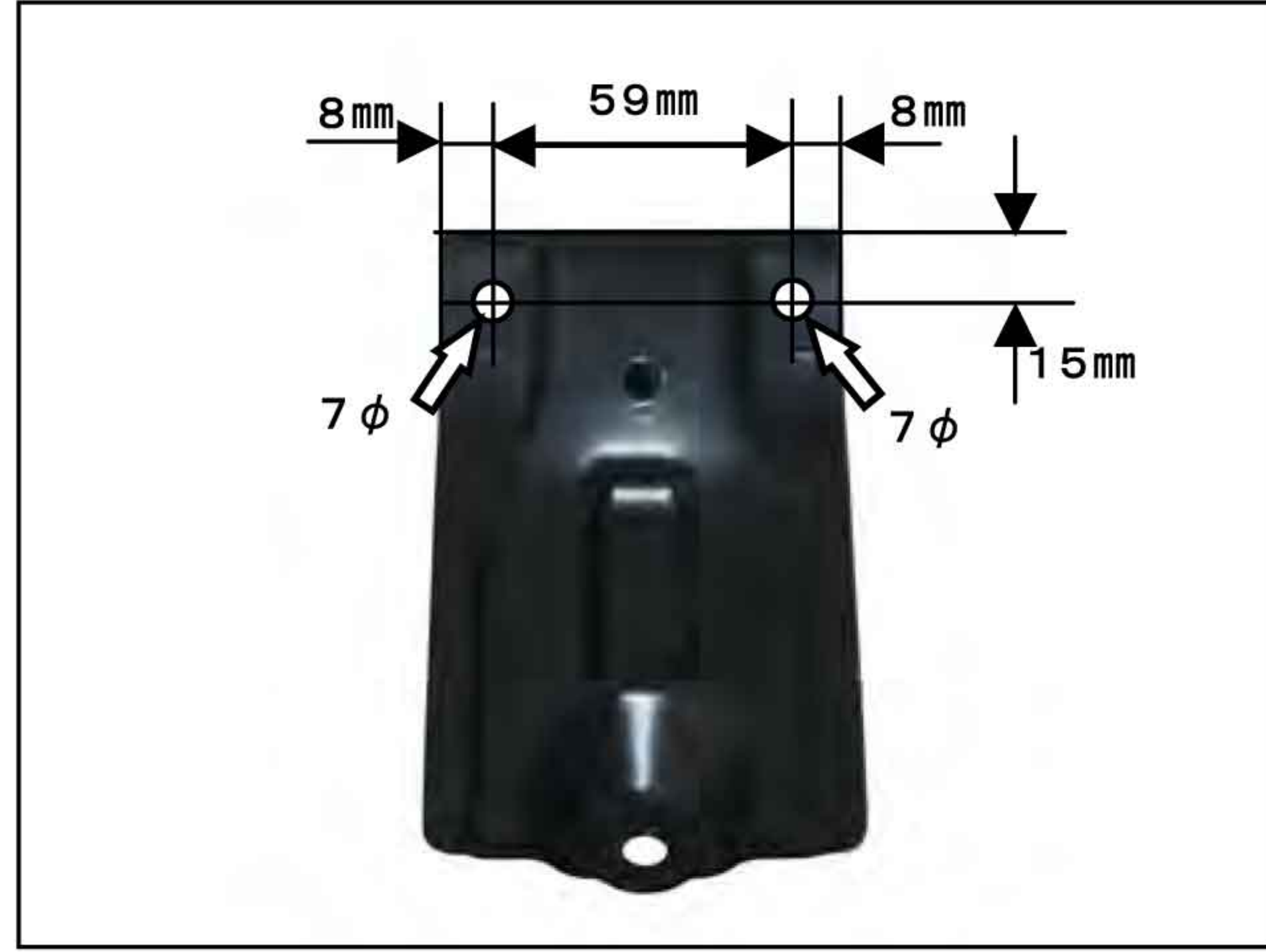
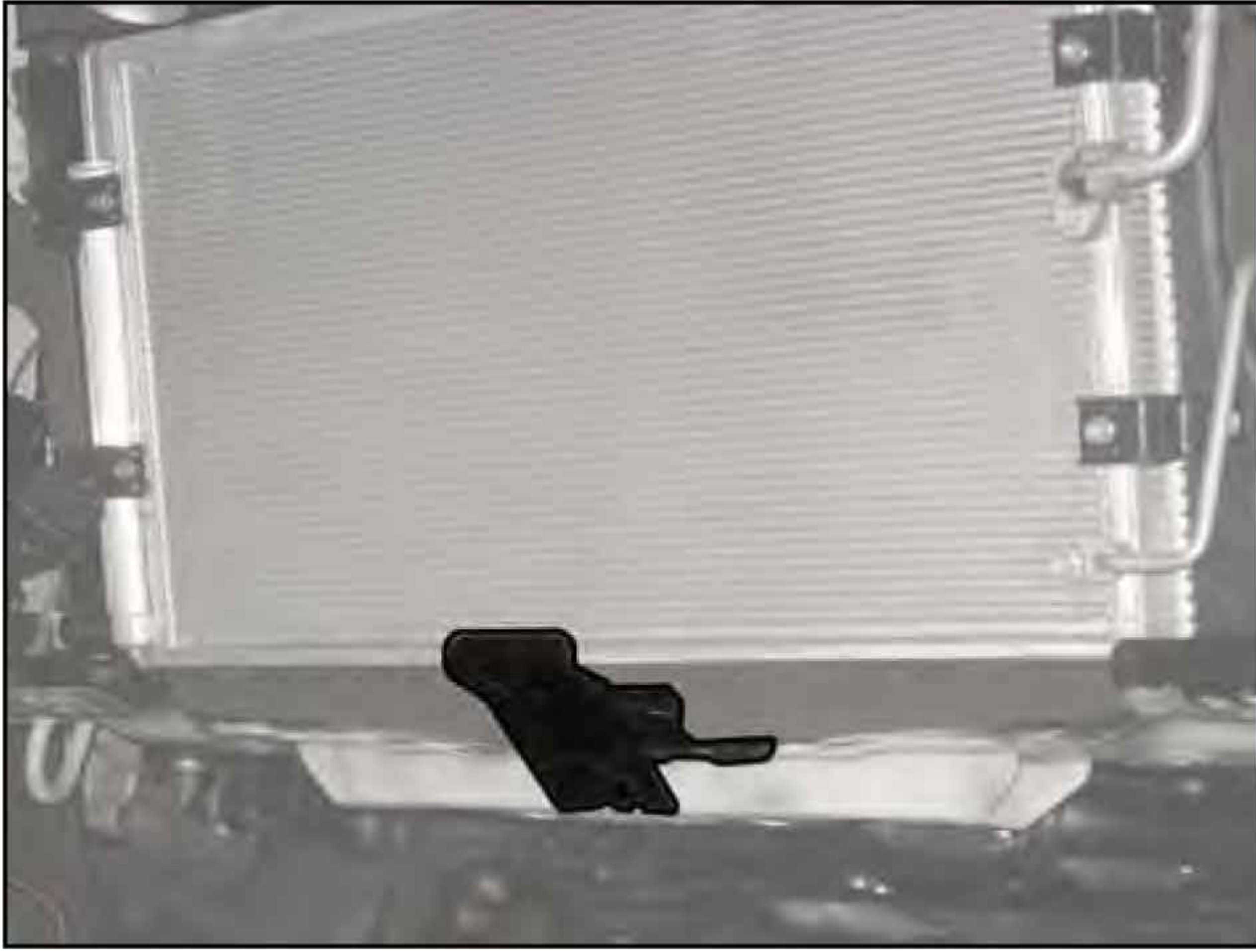

(4) Reinstall the front bumper bracket, then install the Intercooler using the Intercooler Mounting Spacers as shown in the diagram.

〈Parts No.10, 52, 60, 61, 62〉

(1) No.62 M8 × 15mm

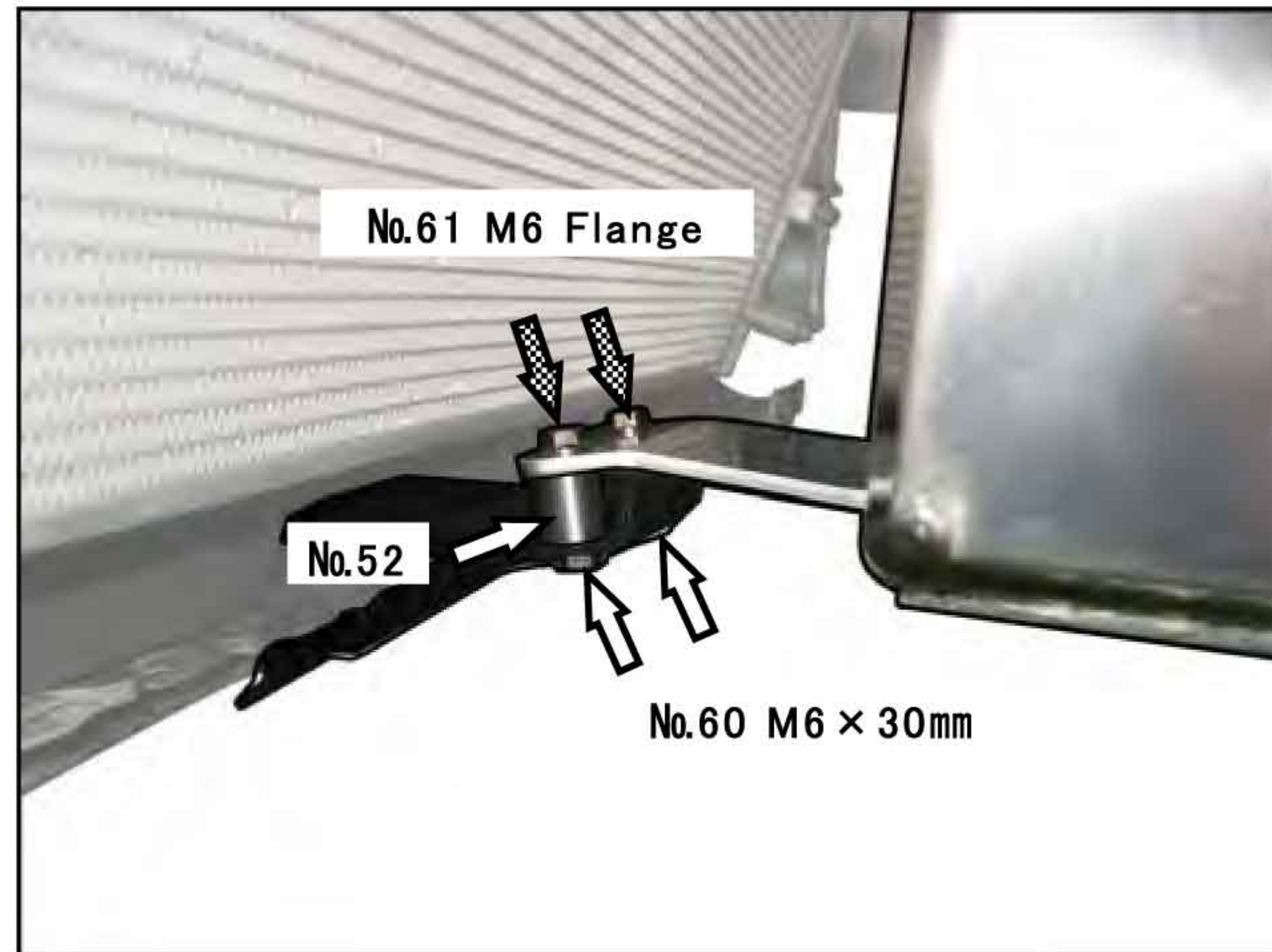

3-13 Compression Tube Installation

(1) Install the 1/8 BST Union Nipple onto the Compression Pipe.

※ Use liquid seal when installing the Union.

〈Part No.5, 19〉



(2) Install Compression Pipes C1 to C-3.

※ Temporarily Finger Tighten.

〈Parts No.5, 6, 7, 25, 27, 32, 34〉

※ also reinstall the factory air diversion panel

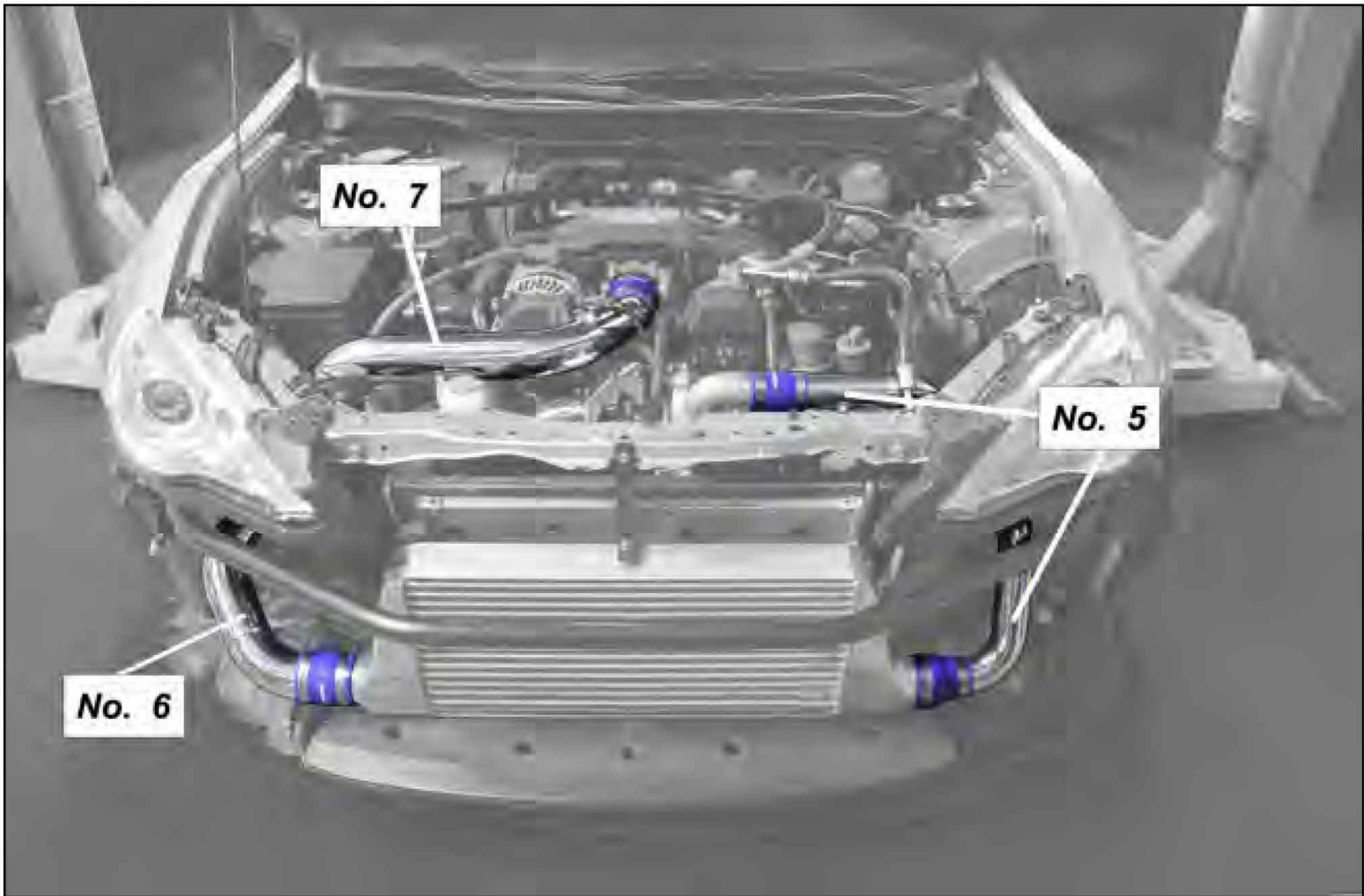

3-14 Intercooler Piping Installation

(1) Connect the Intercooler Piping to the Intercooler and check the clearance. Once the pipes have been connected to the Intercooler, tighten all hose clamps.

〈Parts No.26, 28, 32, 33〉

(2) Install the Airflow Meter.

〈Parts No.55〉

(3) Wrap the Airflow Meter Harness with thermo wrap. Then connect the Airflow Meter Coupler to the Airflow Meter.

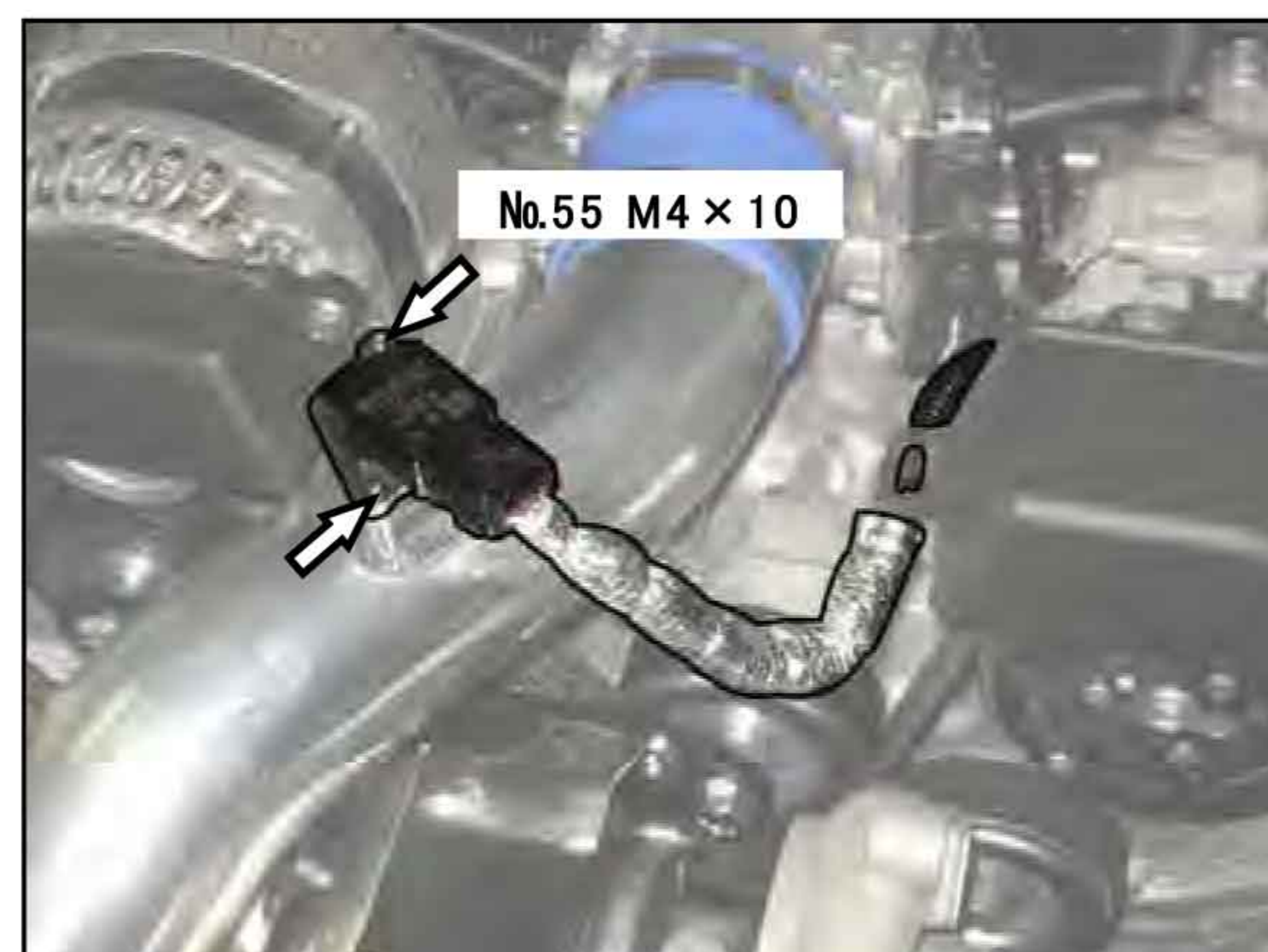

- (4) Connect the Compression Tube and Free Rotation Union to the Turbo Actuator.

〈Parts No.22, 44〉



3-15 Intake Tube Installation

- (1) Install the Air filter element onto aluminum Intake Tube

〈Parts No.8, 9,〉



- (2) Install the Intake Pipe and Intake onto turbocharger inlet.

〈Parts No. 29, 33, 34〉

- (3) Extend the ventilation hose using the 12mm hose union and supplied rubber hose. Connect the extended hose to the Air Intake Tube.

〈Parts No.20, 23, 30〉

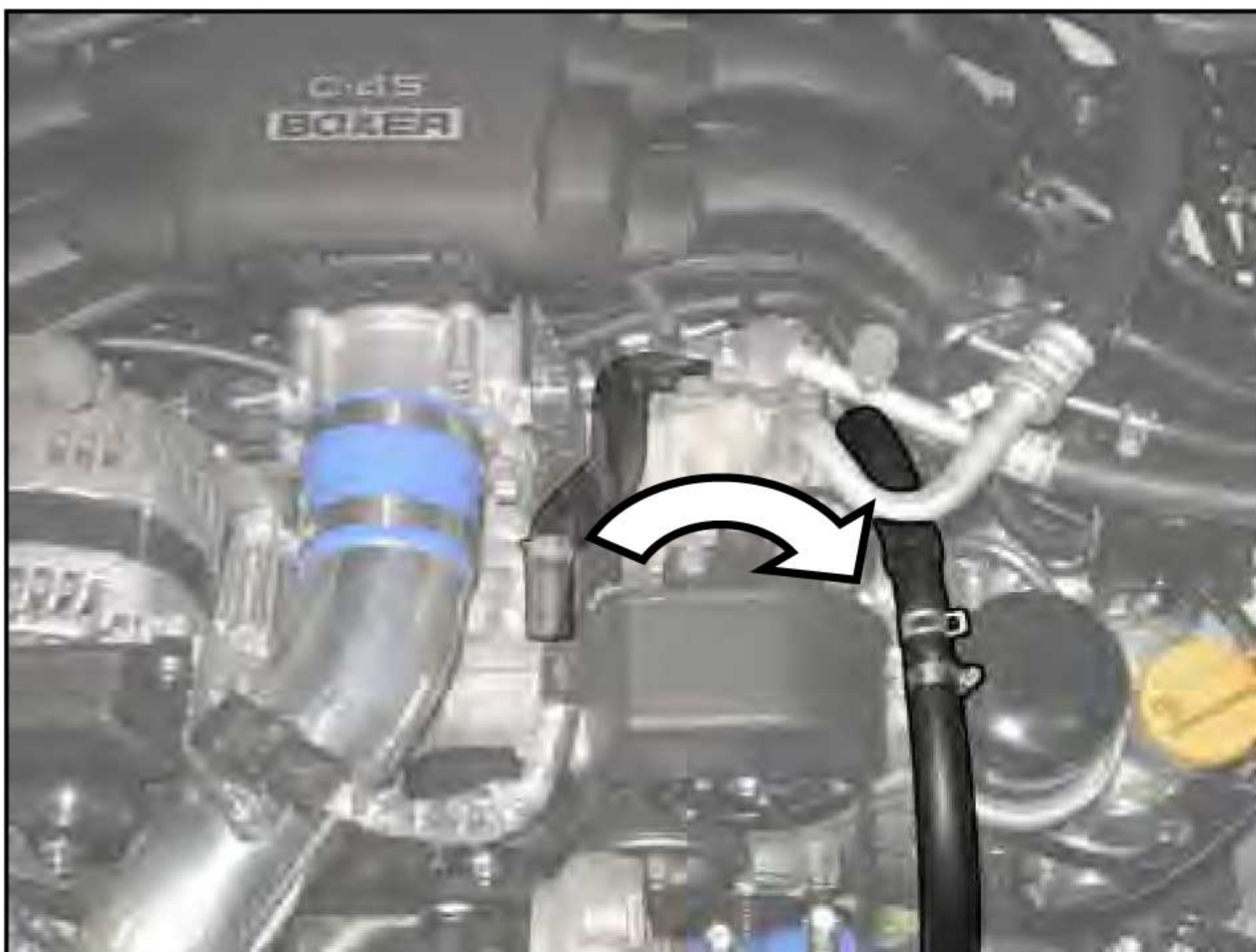

3-16 Engine Start Up

- (1) Replace engine oil, monitor the oil level by checking the oil dipstick..
- (2) Reconnect the Battery Terminals
- (3) Remove the ECU Harness from the ECU and crank the engine by turning the Ignition. This will pressurize the turbo oil feed line.
- (4) Recheck oil level add oil as needed.
- (5) Reconnect the ECU Harness to the ECU and start the engine. Check for any leaks.

3-16 OEM Bumper Installation

- (1) Modify the OEM bumper reinforcement by cutting and or replacing with an off-road aftermarket "bash bar" Make sure that the Intercooler fits in this space.



Be sure to wear proper eye protection when cutting or drilling.

Clean the surface area of any sharp edges and repaint exposed metal.

- (2) Reinstall the washer tank, bumper and undercarriage cover.

4. Power Graph

- This Turbo Kit is designed to boost up to 9.5 to 10.5 PSI.
- ✘ Important This Turbo Kit is not Pre-tuned. The customer or Tuner must select a proper fuel management system. The vehicle & fuel management system must be re-tuned.

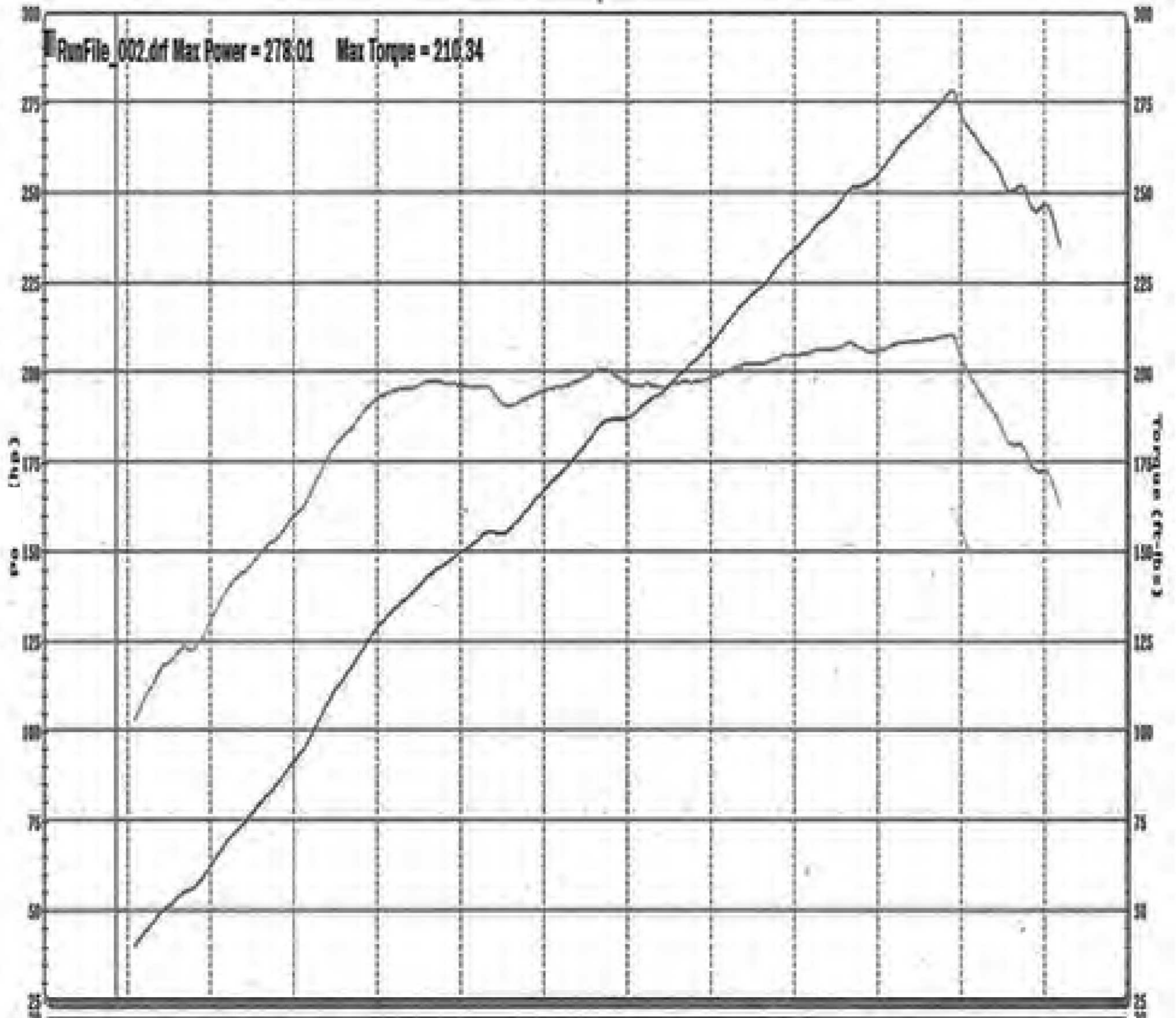

Spec	Max Power WHP/RPM	Max Torque ft-lbs/RPM
GPP GTX2867R Gen 2 @10.29psi	278.01/6900	210.34/6950

- Results may vary.